

LEE COUNTY

NORTH CAROLINA

Committed Today for a Better Tomorrow

**REGULAR MEETING
OF THE
LEE COUNTY BOARD OF COMMISSIONERS**
106 HILLCREST DRIVE
SANFORD, NORTH CAROLINA 27330

January 16, 2018
6:00 P.M.

A G E N D A

CALL TO ORDER – Amy Dalrymple, Chair

INVOCATION – Commissioner Tim Sloan

PLEDGE OF ALLEGIANCE

I. ADDITIONAL AGENDA

- II. APPROVAL OF CONSENT AGENDA** (All items listed below are routine and will be approved by one motion. No separate discussion will be held except by a request of a member of the Board. Any item removed from the Consent Agenda will be considered individually as a part of the regular agenda).
- A. Minutes from the January 2, 2018 Regular Meeting. (Pages 1-6)
 - B. Tax Release and Refund Report for December 2017. (Pages 7-13)
 - C. Minutes from the January 2, 2018 Closed Session Meeting. (Page 14)

III. PUBLIC COMMENTS

IV. OLD BUSINESS

- A. January 2018 Commissioner Retreat. – Chair Dalrymple (Pages 15-17)

V. NEW BUSINESS

- A. Consideration of upgrade to KRONOS system. – Lisa Minter (Pages 18-24)
- B. Discussion of Property Tax Interests and Inclement Weather. – John Crumpton (Pages 25-30)

VI. MANAGERS' REPORTS

- A. County Manager Monthly Report for January 2018. – John Crumpton (Pages 31-67)

VII. PUBLIC HEARING (7:00 P.M.)

- A. Public hearing regarding the lease of space in a spec building at CCEP. – Bob Joyce (Pages 68-71)

VIII. COMMISSIONERS' COMMENTS

ADJOURN

LEE COUNTY

NORTH CAROLINA

Committed Today for a Better Tomorrow

ITEM #:
II. A.

LEE COUNTY AGENDA ABSTRACT BOARD OF COMMISSIONERS MEETING

(Use the Down or Up Arrows to move between fields of the Form)

MEETING DATE: January 16, 2018

SUBJECT: Minutes from the January 2, 2018 Regular Meeting

DEPARTMENT: Governing Body

CONTACT PERSON: Jennifer Gamble, Clerk to the Board

TYPE: Consent Agenda Action Item Public Hearing Information

REQUEST	Approve Minutes from the January 2, 2018 Meeting
BUDGET IMPACT	N/A
ATTACHMENTS	"Draft" copy of the January 2, 2018 Minutes
PRIOR BOARD ACTION	N/A
RECOMMENDATION	Approve Minutes from the January 2, 2018 Meeting
SUMMARY	

A "draft" copy of the Minutes from the January 2, 2018 regular meeting have been prepared for approval. Attachments referenced in the Minutes are available for review in the Clerk's Office located at 408 Summit Drive, Sanford, NC. Once approved, Minutes will be recorded at the Lee County Register of Deeds Office.

LEE COUNTY

NORTH CAROLINA

Committed Today for a Better Tomorrow

REGULAR MEETING
OF THE
LEE COUNTY BOARD OF COMMISSIONERS
106 HILLCREST DRIVE
SANFORD, NORTH CAROLINA 27330

JANUARY 2, 2018

The regular meeting of the Board of Commissioners for the County of Lee, State of North Carolina, convened at 6:00 P.M. in the Commissioners Room, First Floor, Lee County Government Center, 106 Hillcrest Drive, Sanford, North Carolina, on said date. Commissioners present when the meeting was called to order were Amy M. Dalrymple, Dr. Andre Knecht, Larry "Doc" Oldham, Robert T. Reives, Cameron W. Sharpe, and Timothy S. Sloan.

Chair Dalrymple called the meeting to order and the following business was transacted:

Commissioner Sloan delivered the invocation.

The Pledge of Allegiance was recited.

I. ADDITIONAL AGENDA

The Board considered changes/additions to the *Agenda*. With no changes requested, Commissioner Oldham moved to approve the *Agenda* as presented. Upon a vote, the results were as follows:

Aye: Dalrymple, Knecht, Oldham, Reives, Sharpe, Sloan

Nay: None

Absent: Dodson

The Chair ruled the motion had carried.

II. APPROVAL OF CONSENT AGENDA

The Board considered changes to the *Consent Agenda*. With no changes requested, Commissioner Sharpe moved to approve the *Consent Agenda* as amended, which consisted of the following items:

A. Minutes from the December 11, 2017 Regular Meeting.

- B. Minutes from the December 14, 2017 Joint Meeting.
- C. FY 2017/18 Local Emergency Planning Committee Membership Roster.
- D. Award of bid to Deep Trekker for an Underwater Remotely Operated Vehicle for Emergency Management.
- E. Proposed fees for Nexplanon Implant Contraception Removal.
- F. Acceptance of Association of Food and Drug Officials grant funding to enhance conformance with the FDA Voluntary National Retail Food Regulatory Program Standards.
- G. Acceptance of National Association of County and City Health Officials grant funding to enhance conformance with the FDA Voluntary National Retail Food Regulatory Program Standards.
- H. Additional State Revenue for 113 – Electronic Health Record Agreement Addendum.

Upon a vote, the results were as follows:

Aye: Dalrymple, Knecht, Oldham, Reives, Sharpe, Sloan
Nay: None
Absent: Dodson

The Chair ruled the motion had carried.

III. PUBLIC COMMENTS

Pursuant to General Statute § 152A-52.1, Chair Dalrymple opened the floor for *Public Comments*. The following people signed up to speak and were permitted 3 minutes for comments:

1. Jerry Merrit, 2009 Traceway, Sanford, NC (Little River Quarry)
2. Steve Bolstridge, 1427 Carolina Avenue, Sanford, NC (Little River Quarry)
3. Ken Harden, 1352 Ohio Lane, Sanford, NC (Little River Quarry)
4. Kermit Keeten, 231 Lakeview Drive, Sanford, NC (Quarry)
5. Dave Turner, 1746 Daiquiri Turn, Sanford, NC (Court of Appeals Decision)
6. Al Rushatz, 3 Lakeview Drive, Sanford, NC (Quarry)
7. Lois Van Reese, 6004 Cypress Point, Sanford, NC (Quarry)
8. John Altenburger, 3017 Bourbon Street, Sanford, NC (Quarry)
9. Vince Roy, 237 Lakeview Drive, Sanford, NC (Quarry)
10. Henry Kennedy, 564 Chelsea Drive, Sanford, NC (Quarry)
11. Karen Kemerait, 434 Fayetteville Street, Raleigh, NC (Quarry)

IV. OLD BUSINESS

A. Consideration of Contract with WithersRavenel for Park Master Planning Services

The Board approved the selection of WithersRavenel to provide master planning services for Kiwanis Children's Park and O.T. Sloan Park at their meeting on 12/11/2017. Since that time, it has been recommended that Horton and Temple parks also be considered for these services. Finance Director/Assistant County Manager Lisa Minter and Parks and Recreation Director John Payne met with representatives from WithersRavenel

on 12/18/17 to discuss the scope of services to be provided. It was determined at that meeting that WithersRavenel would provide a contract proposal for the original scope of work requested and include separate addendum for Horton and Temple parks for the Board's consideration. Commissioner Oldham moved to approve the proposals for master planning services in the amount of \$90,680.00 for OT Sloan, Kiwanis Children's, Temple and Horton Parks, a copy of which is attached to these minutes and by this reference made apart hereof. Upon a vote, the results were as follows:

Aye: Dalrymple, Knecht, Oldham, Reives, Sharpe, Sloan
Nay: None
Absent: Dodson

The Chair ruled the motion had carried.

V. NEW BUSINESS

A. Request to Appear from the Juvenile Crime Prevention Council

Pamela Glover, Chair of the Juvenile Crime Prevention Council, presented a change in the funding allocation for JCPC. Commissioner Sharpe moved to approve the revised funding decision, a copy of which is attached to these minutes and by this reference made a part hereof. Upon a vote, the results were as follows:

Aye: Dalrymple, Knecht, Oldham, Reives, Sharpe, Sloan
Nay: None
Absent: Dodson

The Chair ruled the motion had carried.

B. FY 2018-19 Budget Procedure Calendar

Finance Director Lisa Minter presented the 2018-19 Fiscal Year Budget Procedure Calendar. Each year a calendar is developed to serve as a guideline for the budget process. This calendar is not a firm calendar and is subject to change especially with regard to budget work sessions that the Board of Commissioners would like to hold. Commissioner Reives moved to approve the FY 2018-19 Budget Procedure Calendar, a copy of which is attached to these minutes and by this reference made a part hereof. Upon a vote, the results were as follows:

Aye: Dalrymple, Knecht, Oldham, Reives, Sharpe, Sloan
Nay: None
Absent: Dodson

The Chair ruled the motion had carried.

C. Budget Amendment # 01/02/18/06

Finance Director Lisa Minter presented Budget Amendment number 01/02/18/06. Commissioner Oldham moved to approve Budget Amendment number 01/02/18/06, a

copy of which is attached to these minutes and by this reference made a part hereof .
Upon a vote, the results were as follows:

Aye: Darlymple, Knecht, Oldham, Reives, Sharpe, Sloan
Nay: None
Absent: Dodson

The Chair ruled the motion had carried.

VI. MANAGER'S REPORTS

A. November 2017 Financial Report

Finance Director Lisa Minter presented the *November 2017 Financial Report*. No action was taken.

County Manager John Crumpton provided an update on the Colon Road Water Project stating that the engineer has all permits in hand and the request for proposals is going out to bid and should come back in February. The anticipated project completion date is April 1, 2018.

VII. COMMISSIONERS' COMMENTS

VIII. CLOSED SESSION

Commissioner Oldham moved to go into *Closed Session* per North Carolina General Statute Section 143-318.11(a)(3) to consult with the County Attorney to preserve the attorney-client privilege in Discussion of the Matter of Little River, LLC v. Lee County and Section 143-318.11(a)(5) to discuss the acquisition of real property. Upon a vote, the results were as follows:

Aye: Dalrymple, Dodson, Knecht, Oldham, Reives, Sharpe, Sloan
Nay: None

The Chair ruled the motion had carried and the Board went into *Closed Session*.

Upon return from *Closed Session*, Commissioner Oldham moved to direct staff to seek a petition of discretionary review in the matter of Little River, LLC vs. Lee County Board of Adjustments. Upon a vote, the results were as follows:

Aye: Dalrymple, Knecht, Oldham, Reives, Sharpe, Sloan
Nay: None
Absent: Dodson

The Chair ruled the motion had carried.

Chair Dalrymple provided a statement on behalf of the Board in support of the local authority of the Lee County Board of Adjustment and the decision of the Lee County

Superior Court and directing the County Attorney to continue working with outside counsel to file a petition for discretionary review with the North Carolina State Supreme Court.

ADJOURNMENT

With no further business to come before the Board, Commissioner Reives moved to adjourn the meeting. Upon a vote, the results were as follows:

Aye: Dalrymple, Knecht, Oldham, Reives, Sharpe, Sloan

Nay: None

Absent: Dodson

The Chair ruled the motion had carried and the meeting adjourned at 8:14 p.m.

Amy M. Dalrymple, Chair
Lee County Board of Commissioners

ATTEST:

Jennifer Gamble, Clerk to the Board

ITEM #:
II. B.

**LEE COUNTY AGENDA ABSTRACT
BOARD OF COMMISSIONERS MEETING**

(Use the Down or Up Arrows to move between fields of the Form)

MEETING DATE: January 16, 2018

SUBJECT: Tax Release and Refund Report for December 2017

DEPARTMENT: Tax Administration

CONTACT PERSON: Mary Yow, Tax Administrator

TYPE: Consent Agenda Action Item Public Hearing Information

REQUEST	Approval of Tax Releases and Refunds for December 2017
BUDGET IMPACT	No
ATTACHMENTS	1) Release Code Descriptions 2) General Statute 105-381 (b) 3) Personal Property Abatement Report 4) Waste Fee Abatement Report 5) Real Property Abatement Report
PRIOR BOARD ACTION	N/A
RECOMMENDATION	Approve Tax Releases and Refunds for December 2017.
SUMMARY	

A release or refund is necessary to adjust or correct an existing tax bill that is in error. North Carolina General Statute 105-381(b) requires the governing body to determine the release or refund of a tax.

RELEASE CODE DESCRIPTIONS

1	ALLOWABLE EXEMPTION NOT APPLIED
2	LAND USE DEFERMENT NOT APPLIED OR ABATEMENT MADE AFTER BILLING
3	PROPERTY DOUBLE LISTED BY TAXPAYER OR TAX OFFICE
4	TAX SITUS OF PROPERTY OUTSIDE JURISDICTION
5	REAL PROPERTY DATA IN ERROR
6	PERSONAL PROPERTY DATA IN ERROR
7	PROPERTY LISTED TO INCORRECT OWNER
8	LAST LIST PENALTY
9	TAXPAYER LISTED PERSONAL PROPERTY THEY DID NOT OWN
10	PROPERTY VALUE APPEALED TO ASSESSOR, BOARD OF E&R OR PROPERTY TAX COMMISSION
11	BUSINESS PERSONAL PROPERTY ASSESSMENT: NO LONGER OWNED OR OUT OF BUSINESS
12	PERSONAL PROPERTY SOLD PRIOR TO JAN 1ST.
13	TAX FORECLOSURE SALE
T	TAXPAYER
TO	TAX OFFICE
LR	LAND RECORDS
TA	TAX APPRAISAL
TOS	TAX OFFICE SOFTWARE
TFS	TAX FORECLOSURE SALE
GP	GARBAGE PICKUP
VA	VACANT OR ADJUSTMENT FOR WASTE FEE
CY	CITY OF SANFORD OR TOWN OR BROADWAY
B	BANKRUPTCY SETTLEMENT
A	AUDIT APPEAL OR ERROR

N.C. Gen. Stat. § 105-381

General Statutes of North Carolina
Copyright 2014 by Matthew Bender & Company, Inc.
a member of the LexisNexis Group.
All rights reserved

*** Statutes current through the 2014 Regular Session ***

CHAPTER 105. TAXATION
SUBCHAPTER 02 . LISTING, APPRAISAL, AND ASSESSMENT OF PROPERTY AND COLLECTION
OF TAXES ON PROPERTY
ARTICLE 27. REFUNDS AND REMEDIES

Go to the North Carolina Code Archive Directory

N.C. Gen. Stat. § 105-381 (2014)

§ 105-381. Taxpayer's remedies

(a) Statement of Defense. -- Any taxpayer asserting a valid defense to the enforcement of the collection of a tax assessed upon his property shall proceed as hereinafter provided.

(1) For the purpose of this subsection, a valid defense shall include the following:

- a. A tax imposed through clerical error;
- b. An illegal tax;
- c. A tax levied for an illegal purpose.

(2) If a tax has not been paid, the taxpayer may make a demand for the release of the tax claim by submitting to the governing body of the taxing unit a written statement of his defense to payment or enforcement of the tax and a request for release of the tax at any time prior to payment of the tax.

(3) If a tax has been paid, the taxpayer, at any time within five years after said tax first became due or within six months from the date of payment of such tax, whichever is the later date, may make a demand for a refund of the tax paid by submitting to the governing body of the taxing unit a written statement of his defense and a request for refund thereof.

(b) Action of Governing Body. -- Upon receiving a taxpayer's written statement of defense and request for release or refund, the governing body of the taxing unit shall within 90 days after receipt of such request determine whether the taxpayer has a valid defense to the tax imposed or any part thereof and shall either release or refund that portion of the amount that is determined to be in excess of the correct tax liability or notify the taxpayer in writing that no release or refund will be made. The governing body may, by resolution, delegate its authority to determine requests for a release or refund of tax of less than one hundred dollars (\$ 100.00) to the finance officer, manager, or attorney of the taxing unit. A finance officer, manager, or attorney to whom this authority is delegated shall monthly report to the governing body the actions taken by him on requests for release or refund. All actions taken by the governing body or finance officer, manager, or attorney on requests for release or refund shall be recorded in the minutes of the governing body. If a release is granted or refund made, the tax collector shall be credited with the amount released or refunded in his annual settlement.

Personal Property Abatement Report

From 12/1/2017 To 12/31/2017

	Value	County Tax	County Penalty	District Tax	District Penalty	Total	Release Code
2017							
Release							
CSF - City of Sanford							
BACHELOR, JIMMY	\$16,380.00	\$130.22	\$0.00	\$98.28	\$0.00	\$228.50	T-4
ROSAS, YULIANA	\$3,590.00	\$28.54	\$2.85	\$21.54	\$2.15	\$55.09	T-3
CSF - City of Sanford Total :	\$19,970.00	\$158.76	\$2.85	\$119.82	\$2.15	\$283.59	
FLS - Lemon Springs Fire District							
COCHRAN, KRISTIN RENEE	\$1,000.00	\$7.95	\$0.80	\$0.96	\$0.10	\$9.80	T-12
COX, MARGARET	\$1,610.00	\$12.80	\$0.00	\$1.55	\$0.00	\$14.35	TA-3
FLS - Lemon Springs Fire	\$2,610.00	\$20.75	\$0.80	\$2.51	\$0.10	\$24.15	
FWP - West Pocket Fire District							
DOVE, DERICK KEITH SR	\$8,660.00	\$68.85	\$6.88	\$12.56	\$1.26	\$89.55	T-3
SPIVEY, ERIC MART	\$2,910.00	\$23.13	\$2.31	\$4.22	\$0.42	\$30.09	T-3
FWP - West Pocket Fire District	\$11,570.00	\$91.98	\$9.19	\$16.78	\$1.68	\$119.64	
Release Total :	\$34,150.00	\$271.49	\$12.84	\$139.11	\$3.93	\$427.38	

Waste Fee Abatement Report

From 12/1/2017 To 12/31/2017

	Solid Waste Fees	Release Code
2017		
Release		
CC - Convenience Center		
HALL, VERNON	\$195.48	VA
HARTS MOBILE PARK INC,	\$1,326.00	VA
TDI DREAMLAND LLC,	\$714.00	VA
TDI DREAMLAND, LLC,	\$408.00	VA
CC - Convenience Center Totals:	\$2,643.48	

SW - Waste Disposal		
MINARD, WILLIAM	\$510.00	VA
MINARD, WILLIAM	\$153.00	VA
POLLARD, BENNY THOMAS	\$204.00	VA
SW - Waste Disposal Totals:	\$867.00	

2016		
Refund		
SW - Waste Disposal		
DICKENS, BELINDA GAIL	\$95.00	VA
SW - Waste Disposal Totals:	\$95.00	

2015		
Refund		
SW - Waste Disposal		
DICKENS, BELINDA GAIL	\$95.00	VA
SW - Waste Disposal Totals:	\$95.00	

2014		
Refund		
SW - Waste Disposal		
DICKENS, BELINDA GAIL	\$90.00	VA
SW - Waste Disposal Totals:	\$90.00	

Waste Fee Abatement Report

From 12/1/2017 To 12/31/2017

Solid Waste Fees

Release Code

2013

Refund

SW - Waste Disposal

DICKENS, BELINDA GAIL

\$90.00

VA

SW - Waste Disposal Totals:

\$90.00

Real Property Abatement Report

From 12/1/2017 To 12/31/2017

	Value	County	City	Fire	Total	Release Code
2017						
Release						
SUBLETT, MICHAEL	\$13,658.00	\$108.58	\$0.00	\$0.00	\$108.58	TA-5
Totals:	\$13,658.00	\$108.58	\$0.00	\$0.00	\$108.58	
FNV - Northview Fire District						
SUBLETT, MICHAEL	\$14,100.00	\$0.00	\$0.00	\$12.27	\$12.27	TA-5
FNV - Northview Fire District	\$14,100.00	\$0.00	\$0.00	\$12.27	\$12.27	
Release Totals:	\$27,758.00	\$108.58	\$0.00	\$12.27	\$120.85	

**LEE COUNTY AGENDA ABSTRACT
BOARD OF COMMISSIONERS MEETING**

ITEM #:
II. C.

(Use the Down or Up Arrows to move between fields of the Form)

MEETING DATE: January 16, 2018

SUBJECT: Minutes from the January 2, 2018 Closed Session Meeting

DEPARTMENT: Governing Body

CONTACT PERSON: Jennifer Gamble, Clerk to the Board

TYPE: Consent Agenda Action Item Public Hearing Information

REQUEST	Approve Closed Session Minutes from the January 2, 2018 Meeting
BUDGET IMPACT	N/A
ATTACHMENTS	Minutes are in a sealed envelope included in each Commissioner's agenda package.
PRIOR BOARD ACTION	N/A
RECOMMENDATION	Approve Minutes as presented
SUMMARY	

A "draft" copy of the Minutes from the January 2, 2018 Closed Session Meeting of the Board has been prepared and provided for the Board's review.

ITEM #:
IV. A.

LEE COUNTY AGENDA ABSTRACT BOARD OF COMMISSIONERS MEETING

(Use the Down or Up Arrows to move between fields of the Form)

MEETING DATE: January 16, 2018

SUBJECT: January 2018 Commissioner Retreat

DEPARTMENT: Administration

CONTACT PERSON: Michael Silverman

TYPE: Consent Agenda Action Item Public Hearing Information

REQUEST	N/A
BUDGET IMPACT	N/A
ATTACHMENTS	Draft of January Board Retreat Agenda
PRIOR BOARD ACTION	N/A
RECOMMENDATION	N/A

SUMMARY

Attached is a draft of the agenda for the upcoming Lee County Commissioners Retreat on January 25th and 26th. This agenda is presented to the board to determine if any revisions or items need to be added at this time. If there are no revisions that need to be made this draft will serve as the finalized agenda.

LEE COUNTY BOARD OF COMMISSIONERS PLANNING RETREAT

SAN-LEE NATURE CENTER MULTI-PURPOSE ROOM
572 PUMPING STATION ROAD
SANFORD, NORTH CAROLINA 27330

JANUARY 25, 2018
5:30 PM

JANUARY 26, 2018
9:00 AM

Thursday, January 25, 2018 – 5:30 PM

DINNER (Catered In) – (Fatt’s)

CALL TO ORDER – Amy Dalrymple, Chair

INVOCATION – Commissioner Doc Oldham

OPENING COMMENTS – Amy Dalrymple, Chair

- I. County Communications Plan– Jamie Brown

RECESS

Friday, January 26, 2018 – 9:00 AM

8:30 AM

BREAKFAST (Catered In) – A light Breakfast will be available at the San-Lee Nature Center Multi-Purpose Room.

Breakfast Items – Mini Doughnuts (Sandra’s Bakery); Chicken Minis (Chick-Fil-A); Fruit Tray (Lowe’s Food), Coffee (Lowe’s Food), Juice (Lowe’s Food).

9:00 AM

- II. K-14 Joint Education Presentation - Dr. Bryan and Dr. Marchant

10:15 AM

- III. Agenda Management – Jennifer Gamble

10:30 AM

BREAK

10:45 AM

- IV. Plan San Lee (Land Use Plan) – Marshall Downey and Don Kovasckitz

11:45 AM

LUNCH (Fresh Choice Café)

12:30 PM

- V. Staff Updates/Follow Up-Items
 - A. Report on Tax Revaluation (Presented by Mary Yow/Michael Brown)
 - B. FY 2019 Budget Discussion
 - C. Analysis of Deciding whether to use LOBs or Private Bank Bids for WB Wicker
 - D. Approach for addressing major upcoming projects
 - E. Addressing Security in County Government Buildings
 - F. Ideas for Addressing Trash Issue
 - G. Development of Opioid Task Force

2:25 PM

CLOSING COMMENTS – Amy Dalrymple, Chair

2:30 PM

Adjourn

LEE COUNTY AGENDA ABSTRACT BOARD OF COMMISSIONERS MEETING

ITEM #:
V. A.

(Use the Down or Up Arrows to move between fields of the Form)

MEETING DATE: January 16, 2018

SUBJECT: Upgrade of the KRONOS timekeeping system

DEPARTMENT: Finance

CONTACT PERSON: Lisa G. Minter, Assistant County Manager/Finance Director

TYPE: Consent Agenda Action Item Public Hearing Information

REQUEST	Approval of scope of work to upgrade KRONOS timekeeping system
BUDGET IMPACT	Up to \$30,375.00
ATTACHMENTS	KRONOS statement of work
PRIOR BOARD ACTION	N/A
RECOMMENDATION	Approval of Statement of Work for Workforce Central Upgrade
SUMMARY	

Lee County installed and started using KRONOS Workforce Central for timekeeping in FY 2007-2008. The system was upgraded in FY 2012-2013. The time has come for the system to be upgraded again to make sure that we are in compliance with FLSA rules and to ensure that we are making effective use of the system. The cost of the upgrade will not exceed \$30,375.00.



Workforce Central Upgrade to v8.0 On Premise

Overview

This Statement of Work ("SOW") provides an overview of the project including scope, approach, costs, and how the project will be managed. To support a successful implementation, the customer will provide the required internal project resources.

Project Objectives

Kronos Professional Services to upgrade Workforce Central from version 6.3 to version 8.x. and successfully install a new implementation of TeleTime IP to replace the existing TeleTime Enterprise version 6.1.1 with (5) lines.

Proposed Solution

Module	Project Type
Workforce Timekeeper	Upgrade
Workforce Manager	Upgrade
Workforce Employee	Upgrade
Workforce Integration Manager	Upgrade
Workforce TeleTime IP Base System (5-lines)	New

Project duration is expected to be 8 weeks, based upon our experience with our customers and products. Depending upon the preparation and engagement of your organization, there may be opportunity to complete the project in a compressed duration. However, if project resources are unprepared or unavailable, the duration of the project may need to be extended, increasing the budget required to successfully complete this scope of work. Requests for additional scope or activities outside of this planned project scope may be accommodated through the change process. In this circumstance, Kronos may issue a change order to ensure the appropriate budget is available.

Kronos will deliver the scope of this project utilizing a remote approach.



Instructor Led Training

Kronos Instructor Led Training is purchased as Training Points. Training Points allow you to budget for training with the flexibility to adjust your plan during implementation.

Core Team training will help your key functional and technical users to make informed solution design, configuration decisions and provide core product knowledge.

Module	Description
Workforce Timekeeper	Public instructor led training for 2

Application Administrator training will prepare you to perform daily and periodic system administration tasks. This training may require pre-requisite knowledge of the core solution functionality.

Module	Description
Workforce Timekeeper	Public instructor led training for 1

Train-the-Trainer Programs prepares internal training teams to deliver user training to managers, supervisors and employees.

Module	Description
Workforce Timekeeper	Public instructor led training for 1



Project Approach

The project team will collaborate to establish a project plan with tasks, responsibilities, and milestone dates and provide the foundation for project control. Kronos will complete an environment readiness review with your project team resources to ensure the server environment is available and pre-requisites have been installed. Kronos will perform test upgrade, deploy interfaces and complete validation testing of upgraded environment. Upon completion of customer user acceptance testing, Kronos will complete the upgrade to production.

Project Leadership

Kronos will provide guidance through the life cycle of the project and provide best practices to implement the solution. As the main point of contact, the Kronos Project Manager will partner with the customer project leadership to develop the project plan to ensure objectives are achieved. The Kronos Project Manager will also deliver a collaborative workspace, which will serve as the dashboard for all aspects of the progress of the implementation.

Solution Assumptions

Workforce Central

- 2 Workforce Central environment(s) included in this deployment
- The Authentication method will be Standard
- 3 existing interface(s) included

Workforce Timekeeper

- 3 Standard Timeclocks will be upgraded



Services Investment Summary

This SOW represents a time and materials engagement. Travel expenses are not included and will be invoiced separately as incurred.

Service Type	
Professional Services	\$28,440.00
Educational Services	\$1,935.00
	\$30,375.00





Signatures and Approvals

SUBMITTED AND APPROVED BY KRONOS REPRESENTATIVE

By: _____ Date: _____

Title: _____

This Statement of Work is subject to the LEE COUNTY - SANFORD NC's agreement with Kronos governing Professional and Education Services. By signing below, the authorized LEE COUNTY - SANFORD NC's representative agrees to purchase the services described herein.

ACCEPTED AND AGREED
LEE COUNTY - SANFORD NC

By: _____ Date: _____

Title: _____

LEE COUNTY - SANFORD NC may make necessary copies of this document for the sole purpose of facilitating internal evaluation and/or execution of proposed project. Otherwise, the document or any part thereof may not be reproduced in any form without the written permission of Kronos Incorporated. All rights reserved. Copyright 2017.



LEE COUNTY AGENDA ABSTRACT BOARD OF COMMISSIONERS MEETING

ITEM #:
V. B.

(Use the Down or Up Arrows to move between fields of the Form)

MEETING DATE: January 16, 2018

SUBJECT: Property Tax Interest and Inclement Weather

DEPARTMENT: Tax/Administration

CONTACT PERSON: John Crumpton/Mary Yow/Whitney Parrish

TYPE: Consent Agenda Action Item Public Hearing Information

REQUEST	Consider the issues surrounding late tax payments and closing of the County offices due to inclement weather on January 4 and January 5, 2018.
BUDGET IMPACT	Will be provided at the meeting – possible refunding of interest collected on January 8, 2018 for late payments.
ATTACHMENTS	1) Email from Christopher McLaughlin – NC School of Government 2) BlogPost from the NC School of Government
PRIOR BOARD ACTION	N/A
RECOMMENDATION	Pleasure of the Board
SUMMARY	

January 5 was the last day to pay property taxes without interest accruing on property tax bills. Due to the tax office being closed on January 4 and closed for 4 hours on Friday, some taxpayers were not able to pay their taxes in person. One complaint centered on “notification” of the times we were open on Friday. The attached information from the School of Government covers the law for when taxes are due and when interest must accrue on the tax bills. By state statute, staff cannot waive interest or penalties. The Commissioners can waive interest or penalties, but could become personally liable for those amounts if the County is sued by any lee county taxpayer. Due to the few complaints we received, we felt that the commissioners needed to review the issue.

John Crumpton

From: Whitney Parrish
Sent: Monday, January 8, 2018 10:44 AM
To: John Crumpton
Subject: FW: Property Tax and Inclement Weather

FYI

From: Mclaughlin, Christopher B [mailto:mclaughlin@sog.unc.edu]
Sent: Monday, January 08, 2018 9:23 AM
To: Whitney Parrish <wparrish@leecountync.gov>
Subject: RE: Property Tax and Inclement Weather

Whitney, that is a call for your board and their attorney. As I said in the post, the Machinery Act does not authorize this action. So, at the end of the day the county is making its own rules. I doubt that anyone would sue over the county choosing to delay the interest date. But in my view making this decision retroactively is more problematic than announcing the change last week. The problem with doing it after the fact is that taxpayers may complain that had they known that payment today would avoid interest they would have visited the office today. Assuming the delinquency date isn't moved, paying tomorrow is exactly the same as paying today, so they have no incentive to pay today without notice of the change. You may have some angry taxpayers who claim they would have paid today had they known in advance that the delinquency date was being moved.

Chris



Christopher B. McLaughlin
Associate Professor of Public Law and Government
School of Government
The University of North Carolina at Chapel Hill
Campus Box 3330, Knapp-Sanders Building
Chapel Hill, NC 27599-3330
T: 919.843.9167 F: 919.962.0654
www.sog.unc.edu

E-mails sent to or from this e-mail address that relate to the School of Government's work are public records and may be subject to public access under the North Carolina public records law.

From: Whitney Parrish [mailto:wparrish@leecountync.gov]
Sent: Monday, January 08, 2018 9:11 AM
To: Mclaughlin, Christopher B <mclaughlin@sog.unc.edu>
Subject: Property Tax and Inclement Weather

Hey! I just finished reading your blog post about property taxes and inclement weather. My question is what if the County was open on a modified schedule on Friday? We were closed all day on Thursday then were open 11-4 on Friday. Do you think we could still pass a resolution moving the date to Monday, January 8? Also, would that be something done just at our next board meeting and those who paid their taxes today would benefit from that resolution? Thanks for your help.

Thanks!

Whitney Parrish
Lee County Attorney
408 Summit Drive
Sanford, NC 27330
919-718-4610 ext. 5518

This email and any files transmitted with it are confidential and intended solely for the sender and receiver. If you are not the named addressee you should not disseminate, distribute, copy or alter this email. Any views or opinions presented in this email are solely those of the author and might not represent those of Lee County Government. Warning: Although Lee County Government has taken reasonable precautions to ensure no viruses are present in this email, the company cannot accept responsibility for any loss or damage arising from the use of this email or attachments. This email message, and any attachment(s) hereto, as well as any email message(s) that may be sent in response to it, may be considered Public Record subject to the North Carolina Public Records Law "NCGS.Ch.132" and may be disclosed to third parties and as such are subject to requests for review without the consent of the sender and/or receiver. If you are not the intended recipient, please destroy this message and inform the sender immediately. The information contained in this email may be confidential and, in any event, is intended only for the use of the entity or individual to whom it is addressed

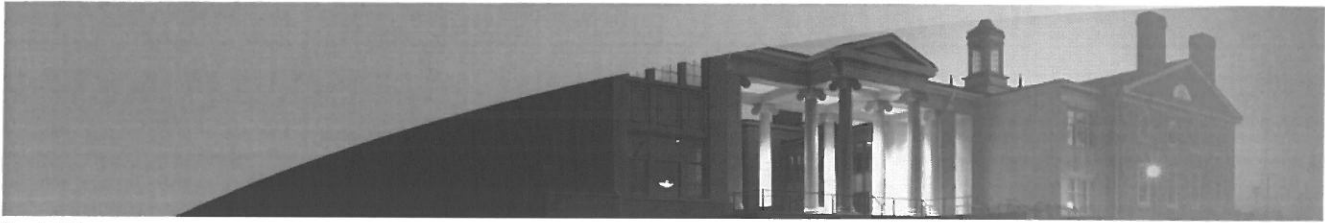

Coates' Canons:
[NC Local Government Law](#)



- [About this Blog](#)
- [About the Authors](#)

Let it Snow!?!? Interest and Inclement Weather

About the author

Chris McLaughlin



[View Other Posts](#)

This entry was posted on January 3rd, 2018 and is filed under [Finance & Tax](#), [Property Taxes](#).



Facebook postings of icebergs floating off the coast of Nags Head are fake news, but snow and ice is in fact predicted for eastern North Carolina over the next few days. This storm is poorly timed for last-minute taxpayers because the [delinquency date](#) for 2017 property taxes is this Saturday, January 6. If taxpayers don't pay their 2017 taxes by Friday, they will accrue 2% interest for the month of January.

The possible collision of ice and interest has caused many county officials to contact me with this question:

If the county tax office is closed on Friday due to inclement weather, may the county move the delinquency date to next week and allow taxpayers to pay their 2017 property taxes without interest on Monday, January 8?

The legal, technical answer is "no." But the practical answer is "it's probably okay if your commissioners and attorney sign off on that decision."

Here's why the technical answer is no: [G.S. 105-395.1](#) moves a taxpayer deadline to the next business day when that deadline to act falls on day on which the county offices are closed due to a weekend or holiday. Because the deadline to pay 2017 property taxes falls on a Friday this year, the weekend-and-holiday rule would not normally come into play.

Coates' Canons Blog: Let it Snow!?!? Interest and Inclement Weather

By Chris McLaughlin

Article: <https://canons.sog.unc.edu/let-snow-interest-inclement-weather/>

This entry was posted on January 03, 2018 and is filed under Finance & Tax, Property Taxes



Facebook postings of [icebergs floating off the coast of Nags Head](#)

are fake news, but snow and ice is in fact predicted for eastern North Carolina over the next few days. This storm is poorly timed for last-minute taxpayers because the delinquency date for 2017 property taxes is this Saturday, January 6. If taxpayers don't pay their 2017 taxes by Friday, they will accrue 2% interest for the month of January.

The possible collision of ice and interest has caused many county officials to contact me with this question:

If the county tax office is closed on Friday due to inclement weather, may the county move the delinquency date to next week and allow taxpayers to pay their 2017 property taxes without interest on Monday, January 8?

The legal, technical answer is "no." But the practical answer is "it's probably okay if your commissioners and attorney sign off on that decision."

Here's why the technical answer is no: G.S. 105-395.1 moves a taxpayer deadline to the next business day when that deadline to act falls on day on which the county offices are closed due to a weekend or holiday. Because the deadline to pay 2017 property taxes falls on a Friday this year, the weekend-and-holiday rule would not normally come into play.

However, G.S. 105-395.1 does not authorize moving taxpayer deadlines when offices are closed due to bad weather, fire damage, or any reason other than a weekend or holiday. Combine that omission with the prohibition on waiving interest created by G.S. 105-380/-381, and that leads us to the technical answer that counties are not authorized to move interest deadlines because of bad weather.

The result doesn't change even if a state of emergency is declared by the governor or by a local government. Neither our state's chief executive or our local governments are authorized to waive state property tax laws when dealing with natural disasters. (See G.S. 166A-19.31 for a description of the powers granted to counties and municipalities when they declare local states of emergency.)

BUT . . . even if the letter of G.S. 105-395.1 doesn't authorize moving deadlines due to unexpected office closures, the spirit of that statute does. The motivation behind the weekend-and-holiday rule is to give taxpayers one additional day to perform an action if county offices are closed on the day the deadline to take that action occurs. If this storm closes county offices on Friday, it makes sense that taxpayers should be given until Monday to make payments without interest. (The IRS made a similar move

for some federal taxpayers after a big late-winter snow storm earlier this year.)

The decision to extend the payment deadline carries some legal risk. Someone could sue the county and claim that moving the deadline constituted an illegal waiver of interest under G.S. 105-381. If that lawsuit were successful, county commissioners who authorized the move could be held personally responsible for the waived interest payments under G.S. 105-381(c).

I think that legal risk is low. Nevertheless, county tax officials should not make the decision to move the payment deadline on their own. They absolutely need to get approval from their county commissioners, attorney, and/or manager. To be safe, I think the tax collector should ask the commissioners for a formal resolution moving the payment deadline to Monday.

Also remember the postmark rules provides relief to taxpayers regardless of weather closings. Under G.S. 105-360(d), any tax payment submitted by mail that receives a U.S. Postal Service postmark on or before January 5 is considered timely and will not accrue interest regardless of when that payment is actually received by the tax office. Taxpayers worried about the weather should pop their payments in the mail before the flakes begin to fall and they will avoid interest accruals no matter how icy the roads may get later this week.

Links

- i1.wp.com/canons.sog.unc.edu/wp-content/uploads/2018/01/iceberg.jpg
- www.newsobserver.com/news/local/article192614004.html
- canons.sog.unc.edu/january-6-record-ownership-and-delinquent-property-taxes/
- www.ncga.state.nc.us/gascripts/statutes/statutelookup.pl?statute=105-395.1
- canons.sog.unc.edu/waiving-interest-property-taxes/
- www.ncga.state.nc.us/gascripts/statutes/statutelookup.pl?statute=166A-19.31
- www.forbes.com/sites/kellyphillipserb/2017/03/15/irs-offers-additional-time-for-some-taxpayers-due-to-winter-storm-stella/#2fbfbc395802
- www.ncga.state.nc.us/gascripts/statutes/statutelookup.pl?statute=105-381
- www.ncga.state.nc.us/gascripts/statutes/statutelookup.pl?statute=105-360

ITEM #:
VI. A.

LEE COUNTY AGENDA ABSTRACT BOARD OF COMMISSIONERS MEETING

(Use the Down or Up Arrows to move between fields of the Form)

MEETING DATE: January 16, 2018

SUBJECT: County Manager's Monthly Report for January 2018.

DEPARTMENT: Administration

CONTACT PERSON: John Crumpton, County Manager

TYPE: Consent Agenda Action Item Public Hearing Information

REQUEST	County Manager's Monthly Report for the month of January 2018
BUDGET IMPACT	N/A
ATTACHMENTS	<ul style="list-style-type: none"> 1) Monthly Report 2) Monthly Tax Collections Report for December 2017 3) TRC Report for January 2018 4) Building Inspections/Permits Report for December 2017
PRIOR BOARD ACTION	N/A
SUMMARY	

The County Manager has provided his monthly report for the month of January 2018.

County Manager's Report – January 16, 2017

Ongoing Projects

Colon Road Water – The design for extending the water lines is complete. In addition, all permits have been obtained for the project. An advertisement for bids was published on the Lee County Government Website on January 4th. Bids are due to the County on January 24th at the Summit Building. We expect the Commissioners to award the contract at the February 5th meeting. Construction should take 60 days. The anticipated completion date will be April 15, 2018.

Courthouse Renovations – The contract with Moseley Architects has been signed by all parties. The analysis of the facilities will start this month. We expect a preliminary report from Moseley in April.

Parks and Recreation Master Plan – The contract for the Master Planning at Kiwanis Family Park, OT Sloan, Horton and Temple parks has been signed with WithersRavenel. Planning is beginning this month. We will keep the Board updated as this project progresses.

Other Items

Joint Interlocal Committee Meeting – City, Town and County staff on working on a date for the next meeting.

Reports

Lee County Parks and Recreation Advisory Board – Attached is the agenda from the P&R Advisory Board meeting in December.

Tax Report – Please find attached the Tax Collection Summary Report for December.

Community Development/Activity Summary – The Technical Review Committee Agenda Memorandum for December is attached for review.

Building Inspections Report – Please find attached the December Building Inspections Report.

Upcoming Meetings/Events:

January 25 & 26 – Commissioners Board Retreat – San Lee Nature Center

February 5 – Regular Commissioners Meeting

February 6, 2018 – Chamber Annual Membership Banquet

February 19 – Regular Commissioners Meeting

March 3 – 7 – NACO Meeting – Washington DC

March 5 – No Commissioners Meeting

March 19 – Regular Commissioners Meeting

Mary C. Yow, PPS
Tax Administrator
718-4661 ext. 5420

Mary Barbour
Listing Manager
718-4661 ext. 5421



Lisa Faulkner
Appraisal Manager
718-4660 ext. 5413

Denette Fitzpatrick
Collection Manager
718-4662 ext. 5423

Memo

To: John Crumpton, County Manager

From: Mary C. Yow, Tax Administrator

Date: January 9, 2017

Re: Monthly Forced Collection Efforts report for December 2017

December 2017	
Accounts researched	813
Wage garnishments, Escheats and bank attachments issued	49
Accounts Updated with Collection info	38
December total collections (all)	\$ 20,338,696.64
December collections for county only (G01)	\$ 13,205,904.60
Payment Agreements Implemented	2
Letters Sent Requesting Employee Info	70
Reminder Notices Mailed	19,902
New Owner Letters Mailed	559

Sanford/Lee County Zoning & Design Review Dept.

115 Chatham Street, Sanford, NC 27330 Phone 919-718-4656

SANFORD / LEE COUNTY / BROADWAY TECHNICAL REVIEW COMMITTEE (TRC) MEMO

TO: SANFORD / LEE COUNTY / BROADWAY (TRC) MEMBERS

Sanford/Lee Co. Community Development Dept.: Marshall Downey, Director
Sanford/Lee Co. Community Development Dept.: David Montgomery, Long Range-Transportation Planner
Sanford/Lee Co. Zoning & Design Review Dept.: Amy J. McNeill, Zoning Administrator
Sanford/Lee Co. Zoning & Design Review Dept.: Alexandria Voignier, Planner II
Sanford/Lee County Building Inspections Dept.: Chris Riggins, Inspections Administrator
Sanford Public Works Dept. / Engineering Division: Michael Lamping, Civil Engineer 1
Sanford Fire Dept.: Wayne Barber, Chief & Ken Cotton, Deputy Chief / Fire Marshal
Sanford Police Dept.: Jamie Thomas, Major of Field Operations
Lee County Office of Emergency Services: Shane Seagroves, Director & Bill Rogers, Fire Marshal
Lee County Strategic Services Dept.: Don Kovaschitz, Administrator
Lee County Schools: Reid Cagle, Transportation Director & Dr. Jim Atkinson, Asst. Supt. for Aux Serv.
NCDOT: Travis Morgan, District 2 Engineer
CC: TRC "CC" Members, Project Managers/Designers

FROM: SANFORD/LEE COUNTY ZONING & DESIGN REVIEW DEPT.

DATE: 01.04.2018

RE: TRC meeting on **Thursday, January 04, 2018 at 9:00 am** in the Buggy Conference Room of the historic Buggy Company Building at 115 Chatham Street to review the following projects:

TRC-29-17

9:00 AM – Winding Brook Apartments – Site Plan Review

LOCATION: 0 Woodland Ave. Sanford, NC

LEE CO. PIN NO.: 9652-32-2400-00, 9652-32-2185-00, 9652-32-5208-00, 9652-32-4087-00, and 9652-31-3940-00

ZONING: CZ Conditional Zoning (2010/2015)

ACERS: 8.63 +/-

DESCRIPTION: (Revision of plans) Development of a multi-family apartment community with 20; 1 bedroom units and 40; 2 bedroom units. Also proposed a community center, gazebo, covered picnic area, benches and playground. This project received an allocation from the North Carolina Housing Finance Agency (NCHFA).

UTILITIES & ACCESS: Proposed to be served by public water & public sewer.

STREET(S): Proposed Public private.

JURISDICTION: City of Sanford, inside the corporate City limits

APPLICANT: Patrick Theismann | 336.398.2702 | pthesimann@beacon-nc.com

OWNER: Ray Covington | 336.312.3320 | covington2@me.com

PROJECT MANAGER: Ken Bright | 919.356.4687 | kwbright@kenbrightengineering.com

PLANNER: Alexandria Voignier, 919-718-4656, ext. 5399

or alexandria.voignier@sanfordnc.net.

WINDING BROOK APARTMENTS SANFORD, NC

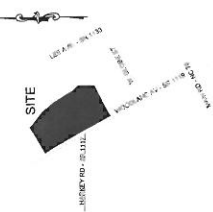

VICINITY MAP - NTS

PRELIMINARY SITE PLAN WINDING BROOK APARTMENTS

OWNER: CCI INNOVATION FAMILY LIMITED PARTNERSHIP
 700 Cleveland Court
 #1000
 Durham, NC 27705

PROPERTY ADDRESS: 0.21073111, 2113 A, 2001 Woodhead Ave,
 Sanford, NC 27330

OWNER: DESIGN MANAGEMENT CO.
 4561 BRIMSTONE DRIVE
 GREENSBORO, NC 27407-2184
 (336) 991-3800

ZONING: WINDING BROOK APARTMENTS - CONDITIONAL ZONING DISTRICT

SETBACKS: FRONT 30', REAR 20', RIGHT OF WAY 20'

SITE DATA: MAX. DENSITY / DUO = 10 COND. DENSITY / UNIT = 1.0
 MAX. GROUND COVER = 35%
 MAX. PERCENT OPEN SPACE = 65%

PERMITTED AREA: 85,000 SQ. FT.

COND. PERMITS: 69,914 SF
 6,431 SF
 3,655 SF
 TOTAL 79,999 SF = 3.14 AC

REFERENCES: 2015 NC GENERAL STATUTES
 CCI 506 P. 476
 CCI 506 P. 478
 CCI 544 P. 238

TAX ID: 962-22-200-00
 962-22-200-00
 962-22-200-00
 962-22-200-00
 962-22-200-00

UTILITIES: WATER, CITY OF SANFORD, 12 IN. MAIN
 WATER, CITY OF SANFORD MULTIPLE METERS, 18' ELEVATION

SPONSOR: AND SITE FEATURES PER SANFORD, NC ZONING AND UTILITY
 SAFETY EASEMENT DEVELOPMENT BY SOROKLAND SURVEYING, PLLC
 2015 GENERAL PLAN, 2015 GENERAL PLAN
 2. BUILDING FLOOR PLANS BY EPRO SURFERN PRINCE ASSOCIATES, PA

Site Information

PARKING REQUIRED: 2 spaces / unit = 2 x 60 = 120
PARKING PROPOSED: = 129

AMENITIES:
 - MULTIPLE ACCESS POINTS
 - TRAFFIC CALMING CENTER
 - TRAFFIC CALMING CENTER
 - TRAFFIC CALMING CENTER
 - TRAFFIC CALMING CENTER
 - TRAFFIC CALMING CENTER

TOTAL AREA: = 8.63 AC
BUILDABLE AREA: = 6.3 AC

NOTES:
 APPROACH TO PARKING: 12'
 MAXIMUM PENALTY \$ 250
 SIGN APPROACH TO PARKING: 12'
 GENERAL SIGNING: 20'-17.8'
 LANDSCAPING: WHITE AND/OR LIGHT BACKGROUND
 SIGNS: WHITE AND/OR LIGHT BACKGROUND
 SIGN APPROACH TO PARKING: 12'
 APPROACH TO PARKING: 12'
 APPROACH TO PARKING: 12'
 APPROACH TO PARKING: 12'

Building Areas

BUILDING TYPE	NO. OF UNITS	GROSS AREA
TOTALS	11	50,198

Building Schedule

BUILDING NO.	BUILDING TYPE	1 BR UNITS	2 BR UNITS	TOTAL UNITS
BUILDING 1	TYPE A	4	0	4
BUILDING 2	TYPE A	2	4	6
BUILDING 3	TYPE A	2	4	6
BUILDING 4	TYPE A	2	4	6
BUILDING 5	TYPE A	2	4	6
BUILDING 6	TYPE A	2	4	6
BUILDING 7	TYPE A	2	4	6
BUILDING 8	TYPE A	2	4	6
BUILDING 9	TYPE A	2	4	6
BUILDING 10	TYPE A	2	4	6
SUBTOTAL		30	40	70



COVER SHEET
WINDING BROOK APARTMENTS
SANFORD, NC

DATE: 12/17/17
 SCALE: AS SHOWN
 CONTRACT: PROJECT # 17-01-211-11

PROJECT: WINDING BROOK APARTMENTS
 PROJECT LOCATION: 2001 WOODHEAD AVENUE, SANFORD, NC 27330

DESIGNER: KEN BRIGHT ASSOCIATES, P.L.L.C.
 1551 WOODHEAD AVENUE, SUITE 111
 SANFORD, NC 27330

CLIENT: WINDING BROOK APARTMENTS
 700 CLEVELAND COURT, SUITE 1000
 DURHAM, NC 27705

REVISIONS:

- C1 COVER
- C2 EXISTING & DEMOLITION PLAN
- C3 PROPOSED SITE PLAN
- C4 UTILITY PLAN
- C5 BUFFER PLAN
- C6 GRADING PLAN
- C7 SITE NOTES
- D1 CIVIL DETAILS
- S1 SEWER DETAILS
- W1 WATER DETAILS

**PRELIMINARY PLAN
 NOT FOR CONSTRUCTION**

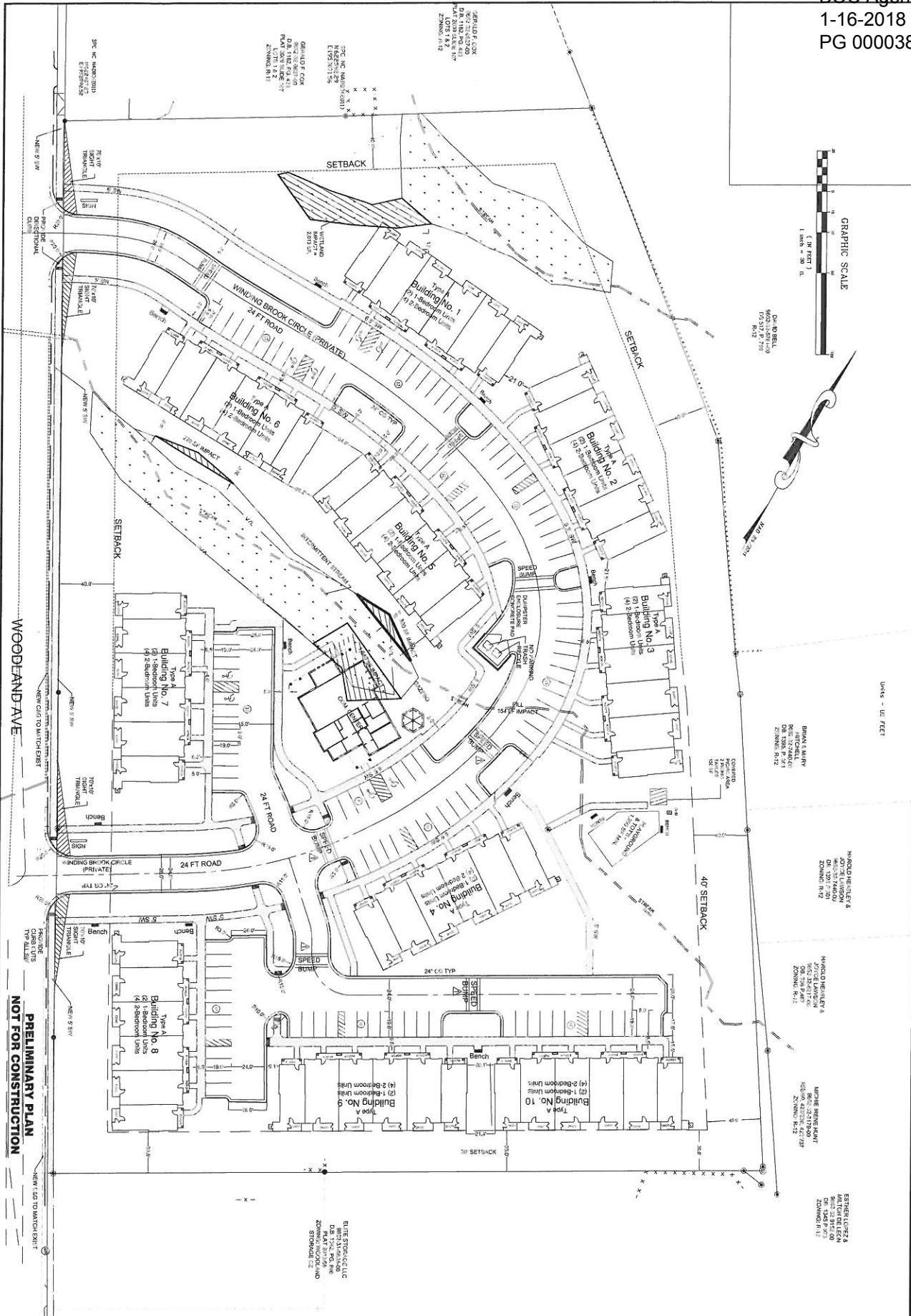

<p>DATE: 12/7/17</p> <p>SCALE: AS SHOWN</p> <p>CONTACT:</p> <p>Patrick J. Thibault Resident Management Corporation 108 Ellingwood Avenue Greenville, NC 27834-2404 Phone: (719) 544-9000, ext. 11</p>	<p>DATE: 12/7/17</p> <p>SCALE: AS SHOWN</p> <p>CONTACT:</p> <p>Patrick J. Thibault Resident Management Corporation 108 Ellingwood Avenue Greenville, NC 27834-2404 Phone: (719) 544-9000, ext. 11</p>	<p>DATE: 12/7/17</p> <p>SCALE: AS SHOWN</p> <p>CONTACT:</p> <p>Patrick J. Thibault Resident Management Corporation 108 Ellingwood Avenue Greenville, NC 27834-2404 Phone: (719) 544-9000, ext. 11</p>	<p>DATE: 12/7/17</p> <p>SCALE: AS SHOWN</p> <p>CONTACT:</p> <p>Patrick J. Thibault Resident Management Corporation 108 Ellingwood Avenue Greenville, NC 27834-2404 Phone: (719) 544-9000, ext. 11</p>	<p>DATE: 12/7/17</p> <p>SCALE: AS SHOWN</p> <p>CONTACT:</p> <p>Patrick J. Thibault Resident Management Corporation 108 Ellingwood Avenue Greenville, NC 27834-2404 Phone: (719) 544-9000, ext. 11</p>
---	---	---	---	---

FILE: C3 OF

PRELIMINARY SITE PLAN
WINDING BROOK
 SANFORD, NC

KEN BRIGHT ASSOCIATES PLLC
 P-0781
 CONSULTING ENGINEERS
 P.O. BOX 151 2300 CANTHAGE ST.
 SANFORD, NC 27331
 PHONE: (919) 776-3444
 e-mail: kbright@kenbrightengineering.com
 www.kenbrighteng.com

REVISIONS:

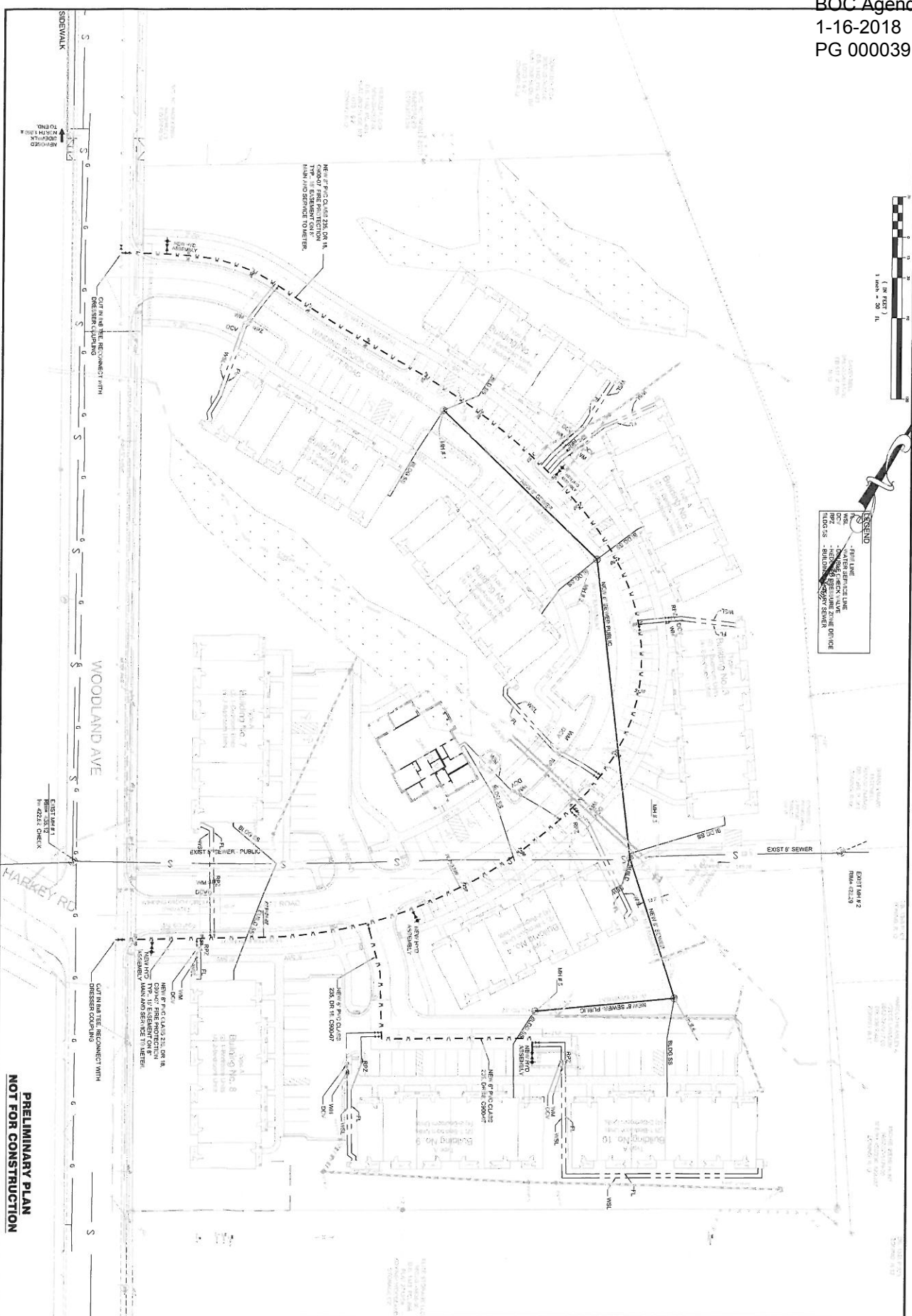

**PRELIMINARY PLAN
 NOT FOR CONSTRUCTION**

<p>DATE: 5/11/17 UTILITY PLAN WINDING BROOK SANFORD, NC</p>	<p>SCALE: AS SHOWN</p>	<p>CONTACT: Patrick J. Thompson Beason Management Corporation 460 Ballboyd Avenue Greenville, NC 27834-2504 Phone: (336) 545-9000, ext. 11</p>	<p>THESE DRAWINGS AND RELATED DOCUMENTS ARE THE PROPERTY OF KEN BRIGHT ASSOCIATES PLLC. ANY REPRODUCTION OR TRANSMISSION OF THESE DRAWINGS WITHOUT THE WRITTEN CONSENT OF KEN BRIGHT ASSOCIATES PLLC IS STRICTLY PROHIBITED.</p>	<p>KEN BRIGHT ASSOCIATES PLLC P-0781 CONSULTING ENGINEERS P.O. BOX 552 2305 CANTHAGE ST. SANFORD, NC 27331 PHONE: (919) 776-3944 e-mail: kb@kenbrightengineering.com www.kenbrightengineering.com</p>	<p>REVISIONS:</p> <table border="1"> <tr><td> </td></tr> <tr><td> </td></tr> <tr><td> </td></tr> <tr><td> </td></tr> <tr><td> </td></tr> </table>					

TYPE A BUFFER 6' MIN. WIDTH
 EXISTING TREES & SHRUBS CAN
 BE COUNTED TOWARD
 REQUIRED LANDSCAPING.

DESCRIPTION	QUANTITY
SMALL SHRUBS (12" TO 24" DIA) (W/2-3" HANGERS)	82
SMALL TREES (8" TO 12" DIA) (W/2-3" HANGERS)	53
SMALL SHRUBS (18" TO 24" DIA) (W/2-3" HANGERS)	47
SMALL TREES (12" TO 18" DIA) (W/2-3" HANGERS)	47
SMALL TREES (18" TO 24" DIA) (W/2-3" HANGERS)	50
SMALL TREES (24" TO 30" DIA) (W/2-3" HANGERS)	17

DESCRIPTION	QUANTITY
SMALL TREES (8" TO 12" DIA) (W/2-3" HANGERS)	13
SMALL TREES (12" TO 18" DIA) (W/2-3" HANGERS)	13
SMALL TREES (18" TO 24" DIA) (W/2-3" HANGERS)	13
SMALL TREES (24" TO 30" DIA) (W/2-3" HANGERS)	13

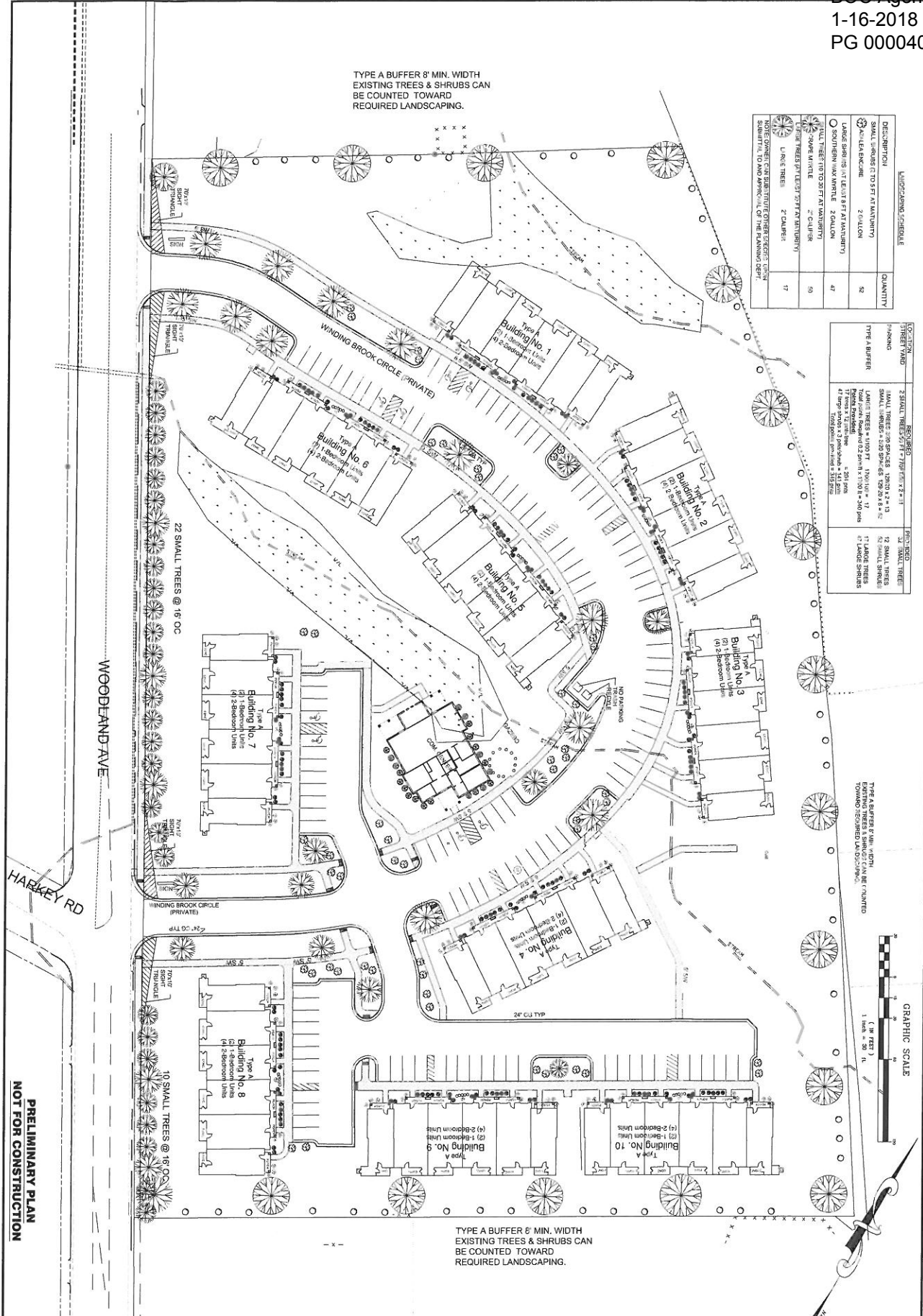

TYPE A BUFFER 6' MIN. WIDTH
 EXISTING TREES & SHRUBS CAN
 BE COUNTED TOWARD
 REQUIRED LANDSCAPING.

PRELIMINARY PLAN
NOT FOR CONSTRUCTION

C5
 FILE OF

DATE: 12/7/17	SCALE: AS SHOWN	CONTACT: Patrick J. Theisen, Beaton Management Corporation, 409 Ballground Avenue, Greensboro, NC 27425-2554, Phone: (733) 545-8000, ext. 11	THESE PLANS AND RELATED DOCUMENTS ARE THE PROPERTY OF KEN BRIGHT ASSOCIATES PLLC. THEY SHALL NOT BE USED, REPRODUCED, COPIED, REPRINTED, OR OTHERWISE TRANSMITTED IN ANY FORM OR BY ANY MEANS, WITHOUT THE WRITTEN PERMISSION OF KEN BRIGHT ASSOCIATES, PLLC.	KEN BRIGHT ASSOCIATES PLLC P-0791 CONSULTING ENGINEERS P.O. BOX 553 2305 CARTHAGE ST. SANFORD, NC 27331 PHONE: (719) 776-3444 e-mail: kb@kenbrightengineering.com www.kenbrightengineering.com	REVISIONS:
---------------	-----------------	--	---	--	------------

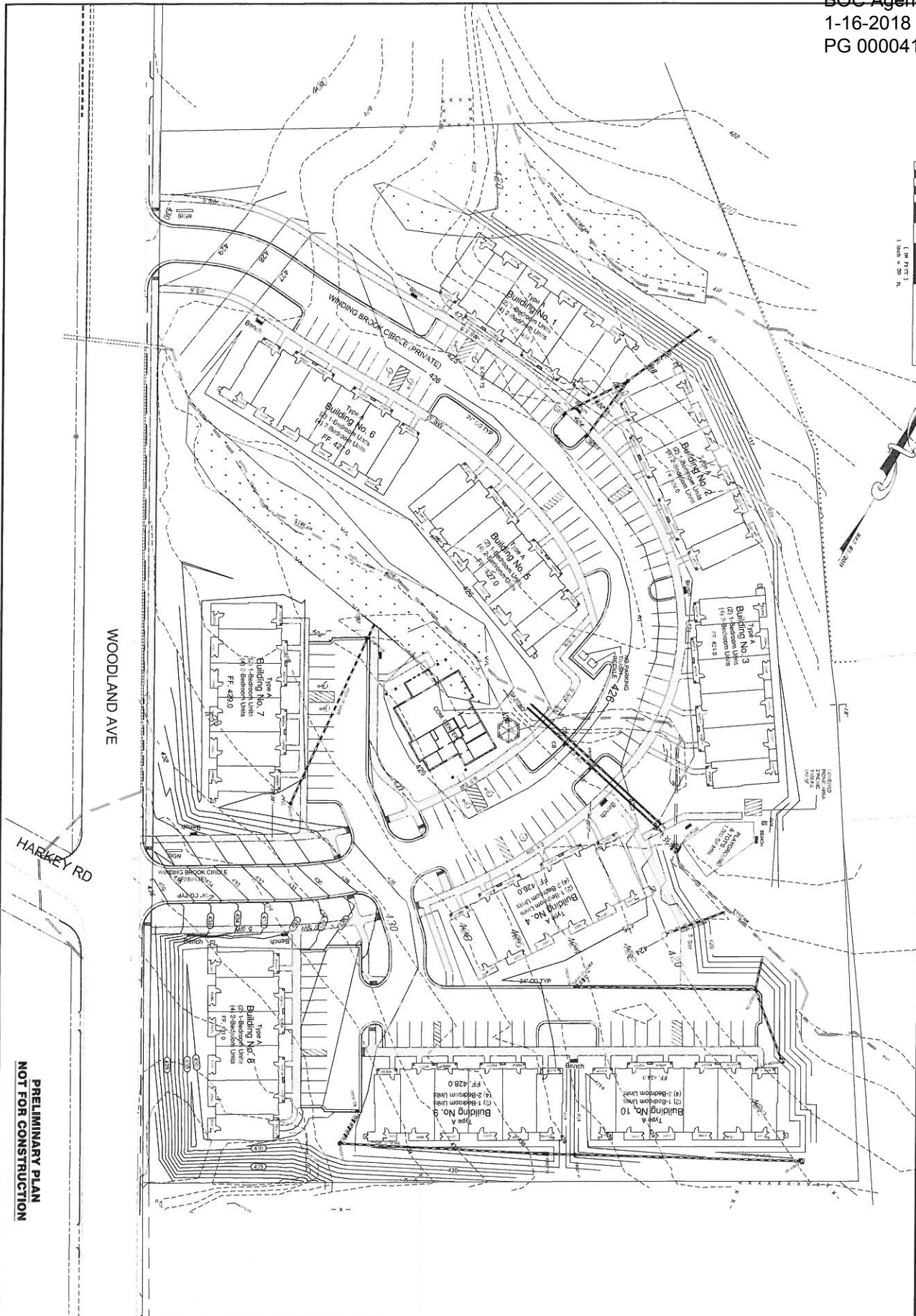

PRELIMINARY PLAN
 NOT FOR CONSTRUCTION

<p>FILE OF</p> <h1 style="font-size: 2em;">C6</h1>	<p>DATE: 12/7/17</p> <p>GRADING & STORM DRAINAGE</p> <p>WINDING BROOK</p> <p>SANFORD, NC</p>	<p>CONTACT:</p> <p>Patrick J. Theobald Business Management Consultant 409 Ballgourd Avenue Greensboro, NC 27409-1304 Phone: (336) 548-1400, ext. 11</p>	<p>THESE DRAWINGS AND RELATED DOCUMENTS ARE THE PROPERTY OF KEN BRIGHT ASSOCIATES, PLLC. THEY SHALL NOT BE REPRODUCED OR TRANSMITTED IN ANY FORM OR BY ANY MEANS, ELECTRONIC OR MECHANICAL, WITHOUT THE WRITTEN PERMISSION OF KEN BRIGHT ASSOCIATES, PLLC.</p>	<p>KEN BRIGHT ASSOCIATES PLLC P-0781 CONSULTING ENGINEERS P.O. BOX 553 2305 CARTHAGE ST. SANFORD, NC 27331 PHONE: (813) 776-3444 e-mail: kbright@kenbrightengineering.com www.kenbrightengineering.com</p>	<p>REVISIONS:</p> <table border="1"> <tr><td> </td><td> </td></tr> <tr><td> </td><td> </td></tr> <tr><td> </td><td> </td></tr> <tr><td> </td><td> </td></tr> </table>								
CONSULTING ENGINEERS 1000 W. WINDING BROOK													

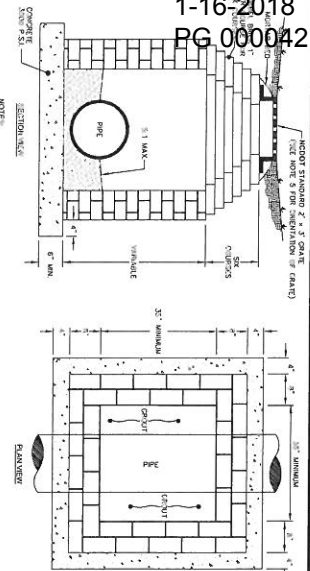

1 STANDARD YARD INLET WITH GRATE AND FRAME

NOTE: 1. MANHOLE SHALL BE CONCRETE OR PRECAST CONCRETE MANHOLE. 2. MANHOLE SHALL BE 3.5" DIA. MANHOLE. 3. MANHOLE SHALL BE 3.5" DIA. MANHOLE. 4. MANHOLE SHALL BE 3.5" DIA. MANHOLE. 5. MANHOLE SHALL BE 3.5" DIA. MANHOLE. 6. MANHOLE SHALL BE 3.5" DIA. MANHOLE. 7. MANHOLE SHALL BE 3.5" DIA. MANHOLE. 8. MANHOLE SHALL BE 3.5" DIA. MANHOLE. 9. MANHOLE SHALL BE 3.5" DIA. MANHOLE. 10. MANHOLE SHALL BE 3.5" DIA. MANHOLE. 11. MANHOLE SHALL BE 3.5" DIA. MANHOLE. 12. MANHOLE SHALL BE 3.5" DIA. MANHOLE.

SHALLOW TYPE
(6 FEET OR LESS IN DEPTH)

INTERMEDIATE TYPE (4'X4')
(6 FEET TO 20 FEET IN DEPTH)

DEEP TYPE (5'X5')
(OVER 20 FEET IN DEPTH)

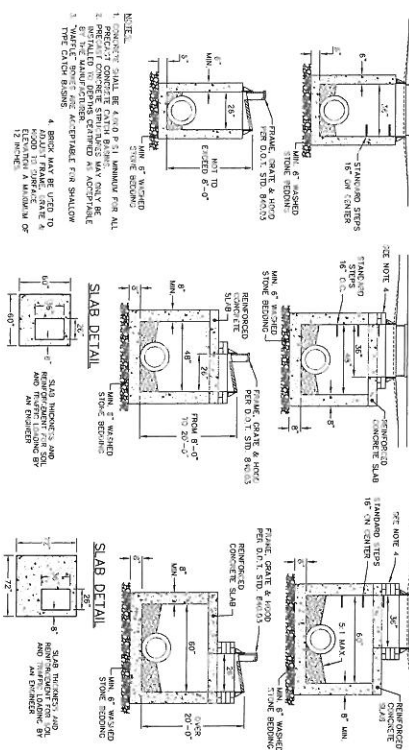

4 STANDARD PRECAST CONCRETE CATCH BASIN

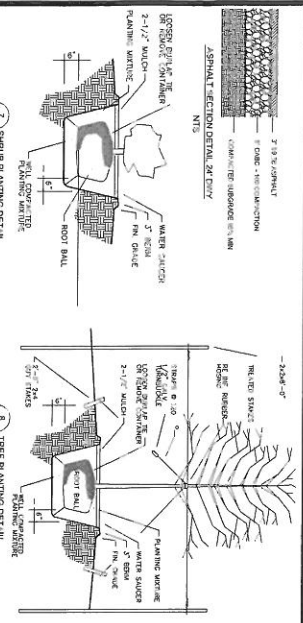

7 CURB & FRAME DETAIL

8 CURB & FRAME DETAIL

STANDARD TYPE
(UP TO 20 FEET IN DEPTH)

DEEP TYPE
(OVER 20 FEET IN DEPTH)

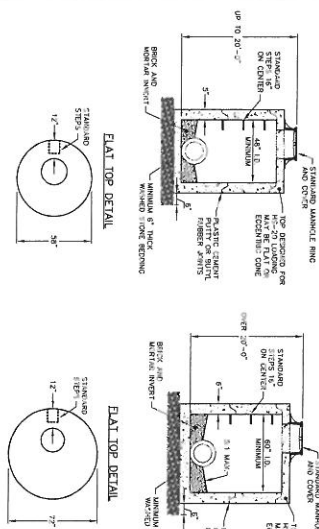

2 STANDARD PRECAST CONCRETE MANHOLE JUNCTION BOX

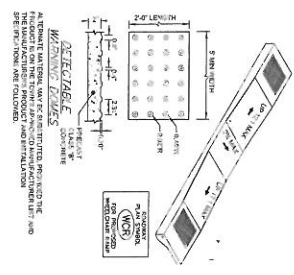

5 WHEELCHAIR RAMP WITH CURB CUT

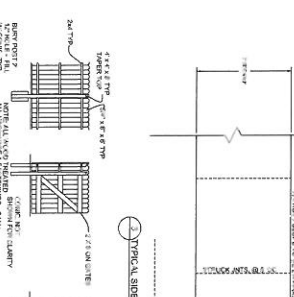

3 TYPICAL ALUMINUM LIGHT FIXTURE

6 WINDSTER WOOD FENCE DETAIL

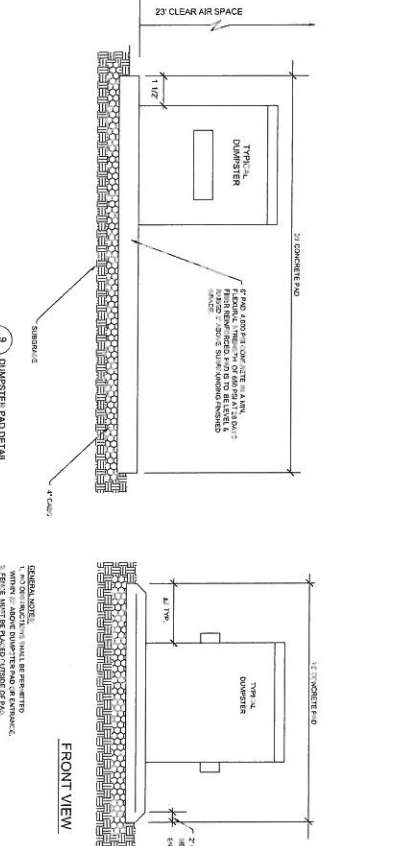

9 DOWNSPOUT PAD DETAIL

FRONT VIEW

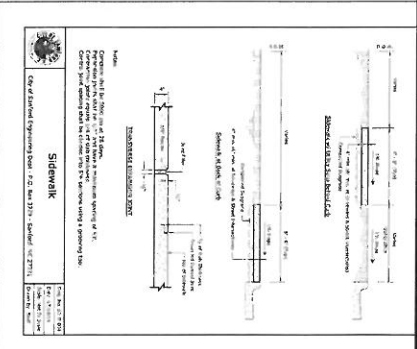

4 SIDEWALK

Ken Bright Associates, PLLC
1000...
P.O. Box 553 2305 Carthage St.
Fayetteville, NC 27803
Phone: (919) 716-5144
www.kerbrightassociates.com

REVISIONS:

Ken Bright Associates, PLLC
1000...
P.O. Box 553 2305 Carthage St.
Fayetteville, NC 27803
Phone: (919) 716-5144
www.kerbrightassociates.com

CONTACT:
P.O. Box 11, Tullahoma
Buckley Management Corporation
401 Bevilacqua Avenue
Greenville, SC 29615-4204
Phone: (1-855) 545-1800, ext. 11

DATE: 12/7/17 SCALE: AS SHOWN
CIVIL DETAILS
WINDING BROOK
SANFORD, NC

D1 OF
10/27/2018 WINDING BROOK

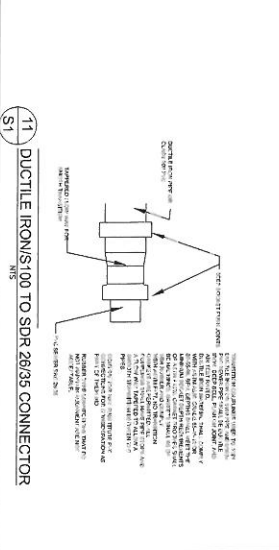
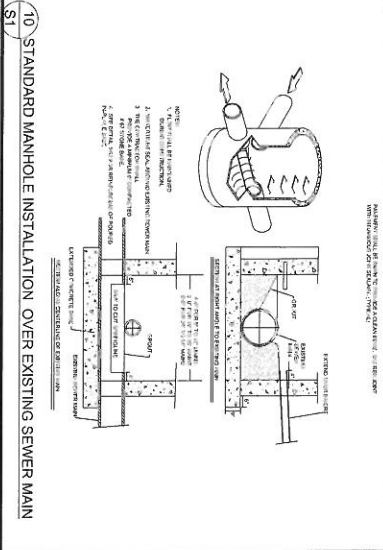
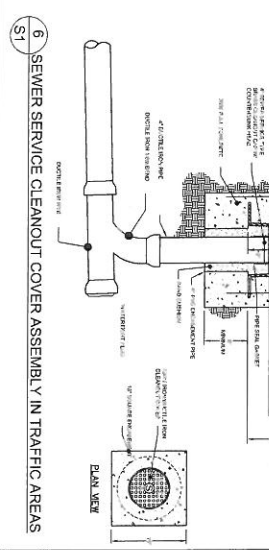
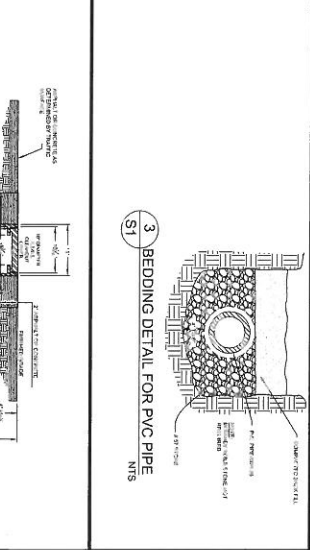
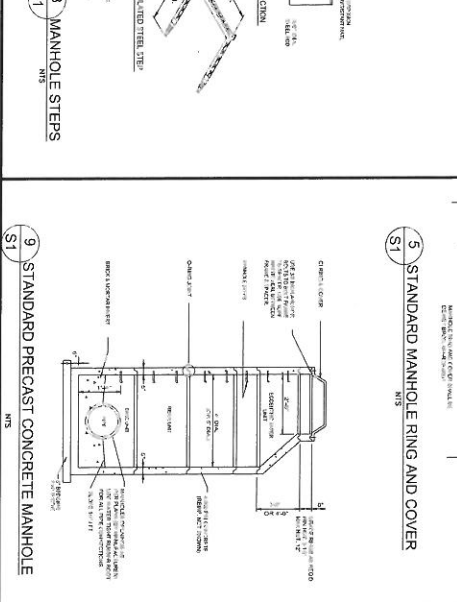
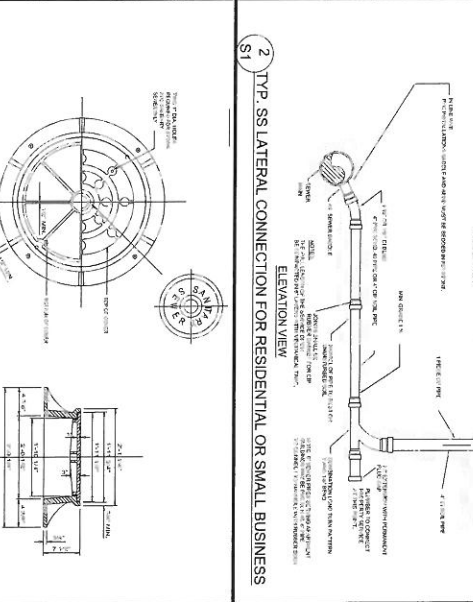
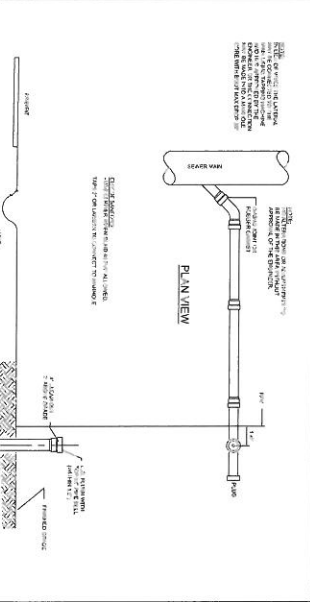
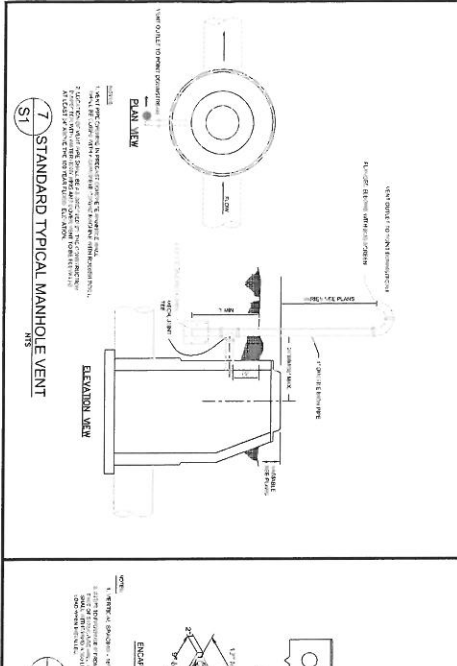
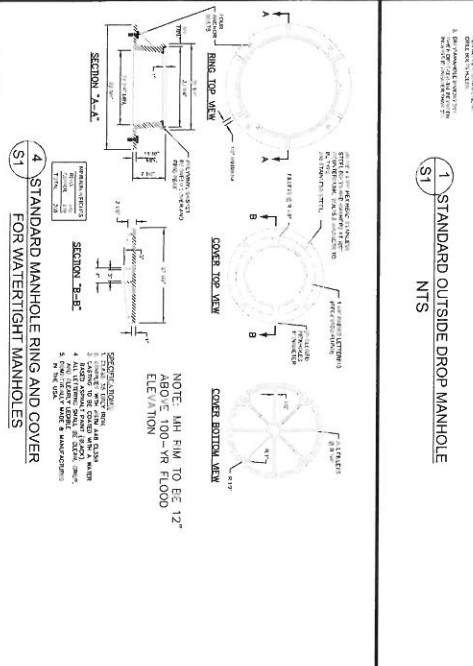
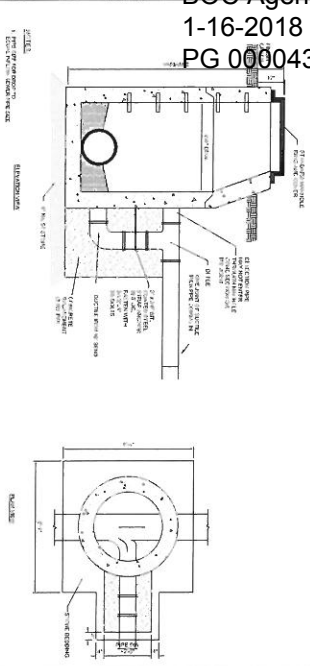

REVISIONS:

KEN BRIGHT ASSOCIATES PLLC
P-0781
CONSULTING ENGINEERS
P.O. BOX 553 2315 CARTHAGE ST.
SANFORD, NC 27331
PHONE: (919) 776-2464
FAX: (919) 776-2464
E-MAIL: k.bright@kenbrightengineering.com
www.kenbrightengineering.com

CONTACT:
Patrick J. Thelmann
Beacon Management Corporation
409 Ralleyground Avenue
Greenville, NC 27634-2914
Phone: (756) 545-8000, ext. 11

SCALE: AS SHOWN
DATE: 12/7/17

SEWER DETAILS
WINDING BROOK
SANFORD, NC

FILE: S1
OF

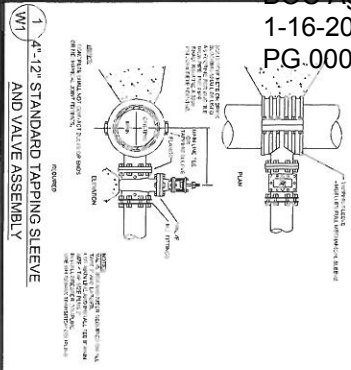

1 4'-12" STANDARD TAPPING SLEEVE AND VALVE ASSEMBLY

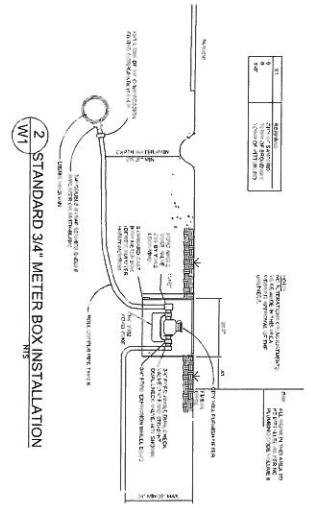

2 STANDARD 3/4" METER BOX INSTALLATION

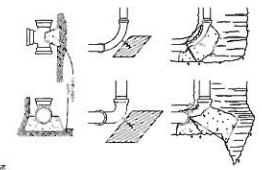

MINIMUM COVER REQUIREMENTS

MINIMUM COVER	12\"/>								
12"	12"	12"	12"	12"	12"	12"	12"	12"	12"
18"	18"	18"	18"	18"	18"	18"	18"	18"	18"
24"	24"	24"	24"	24"	24"	24"	24"	24"	24"
30"	30"	30"	30"	30"	30"	30"	30"	30"	30"
36"	36"	36"	36"	36"	36"	36"	36"	36"	36"
42"	42"	42"	42"	42"	42"	42"	42"	42"	42"
48"	48"	48"	48"	48"	48"	48"	48"	48"	48"
54"	54"	54"	54"	54"	54"	54"	54"	54"	54"
60"	60"	60"	60"	60"	60"	60"	60"	60"	60"
66"	66"	66"	66"	66"	66"	66"	66"	66"	66"
72"	72"	72"	72"	72"	72"	72"	72"	72"	72"
78"	78"	78"	78"	78"	78"	78"	78"	78"	78"
84"	84"	84"	84"	84"	84"	84"	84"	84"	84"
90"	90"	90"	90"	90"	90"	90"	90"	90"	90"
96"	96"	96"	96"	96"	96"	96"	96"	96"	96"
102"	102"	102"	102"	102"	102"	102"	102"	102"	102"
108"	108"	108"	108"	108"	108"	108"	108"	108"	108"
114"	114"	114"	114"	114"	114"	114"	114"	114"	114"
120"	120"	120"	120"	120"	120"	120"	120"	120"	120"

3 STANDARD REACTION BLOCKING

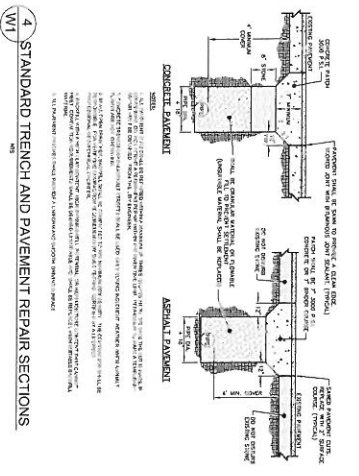

4 STANDARD TRENCH AND PAVEMENT REPAIR SECTIONS

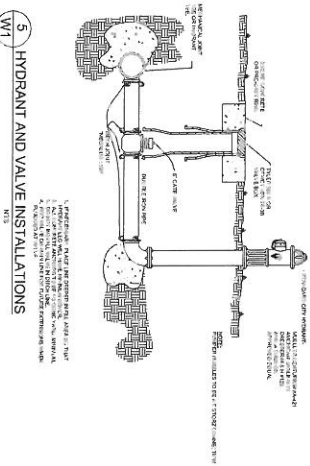

5 HYDRANT AND VALVE INSTALLATIONS

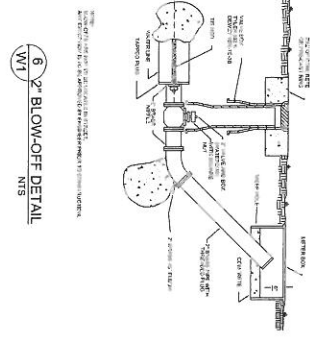

6 BLOW-OFF DETAIL

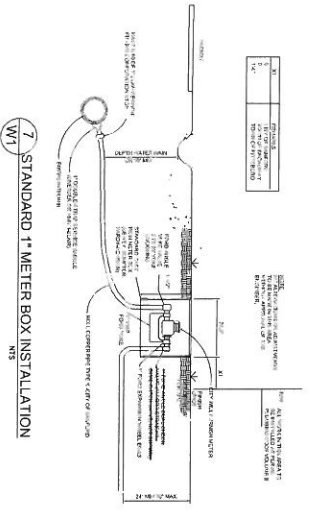

7 STANDARD 1" METER BOX INSTALLATION

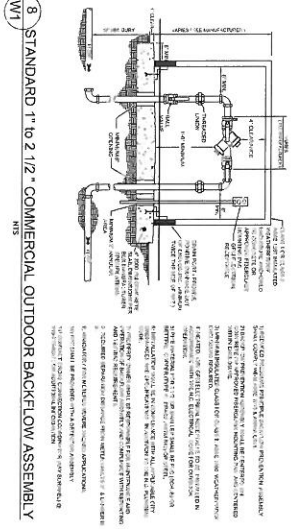

8 STANDARD 1" TO 2 1/2" COMMERCIAL OUTDOOR BACKFLOW ASSEMBLY

Permits Monthly Report
 From 12/1/2017 To 12/31/2017

Change of Occupancy
 <NONE>

Permit #	Location	Sq. Ft.	Valuation	Issued	Contractor	Phone	Owner	District	HRF
OCC-12-17-30070	1952 HORNER BLVD S SANFORD, NC 27330-	0	0	12/22/2017	I INOVATIONS INC.	(919)770-9903	CAROLINA HORNER BOU	City of Sanford	

Number of Change of Occupancy: 1
 Valuation Total: \$0.00

Permits Monthly Report
 From 12/1/2017 To 12/31/2017

Commercial Building Permit Renovation

Permit #	Location	Sq. Ft.	Valuation	Issued	Contractor	Phone	Owner	District	HRF
COMM-12-17-29965	4300 OAK PARK RD SANFORD, NC 27330-	0	0	12/14/2017	JACOBS FIELD SERVICES NORTH AMERICA INC	(919)859-5000	PEIZER	Lee County	
COMM-12-17-29978	2301 BROWN RD SANFORD, NC 27330-	0	0	12/22/2017	DURHAM ROOFING & SHEET METAL INC.	(919)682-8064	C P PROPERTIES INC	Lee County	
COMM-12-17-29984	145 MAIN ST W SANFORD, NC 27330-	0	0	12/21/2017	STERLING-EULISS ENTERPRISES, LLC	(919)771-6677	4A PROPERTIES LLC	City of Sanford	
COMM-12-17-30012	2101 NASH ST SANFORD, NC 27330-	0	0	12/19/2017	WST INDUSTRIES, LLC	(919)775-2320	MAGNETTI MARELLI	City of Sanford	

Number of Commercial Building Permits: 4

Valuation Total: \$0.00

Permits Monthly Report
From 12/1/2017 To 12/31/2017

Agenda
1-1-2018
PG 000047

Demolition Permit
Commercial

Permit #	Location	Sq. Ft.	Valuation	Issued	Contractor	Phone	Owner	District	HRF
DEMO-12-17-30033	1600 COLON RD SANFORD, NC 27331-	0	0	12/20/2017	TRACY GAUTIER	(919)776-4641	CARTER KELLER	Lee County	

Number of Demolition Permits: 1

Valuation Total: \$0.00

Permits Monthly Report
From 12/1/2017 To 12/31/2017

Electrical Permit
B-1-P

Accessory Building

Permit #	Location	Sq. Ft.	Valuation	Issued	Contractor	Phone	Owner	District	HRF
ELEC-12-17-29990	900 GILMORE DR SANFORD, NC 27330-	0	0	12/14/2017	BILLINGS ELECTRIC CO. INC	(919) 258-3115	MICHAEL TATUM	City of Sanford	
ELEC-12-17-30089	1915 CLEARWATER DR SANFORD, NC 27330-	0	0	12/28/2017	DANNY COX	(919) 770-9423	TAMARA BARTMAN	ETJ	

Change Out

Permit #	Location	Sq. Ft.	Valuation	Issued	Contractor	Phone	Owner	District	HRF
ELEC-11-17-29894	1411 PINEHURST ST SANFORD, NC 27330-	0	0	12/01/2017	ECS INC.	(704) 825-7667	BENITA RUTH JONES	City of Sanford	
ELEC-12-17-29946	1302 RAY AVE SANFORD, NC 27330-	0	0	12/07/2017	C & K ELECTRIC & PLUMBING	(919) 776-2044	G&L HORIZON PROPERT	City of Sanford	
ELEC-12-17-29951	1808 CHEROKEE TR SANFORD, NC 27332-	0	0	12/08/2017	TRIPLE "A" ELECTRIC	(919) 353-1982	CHAD THOMAS ASHWOR	City of Sanford	
ELEC-12-17-29997	602 MAIN ST S BROADWAY, NC 27505-	0	0	12/15/2017	A. L. MCKENZIE ELECTRICAL CO	(919) 353-2134	ROBBIE H CASTLEBERR	Town of Broadway	
ELEC-12-17-30088	208 ACORN DR SANFORD, NC 27330-	0	0	12/28/2017	RICKY YARBOROUGH	(919) 770-4078	RICHARD I JR GARNER	City of Sanford	

Commercial

Permit #	Location	Sq. Ft.	Valuation	Issued	Contractor	Phone	Owner	District	HRF
ELEC-12-17-29903	1508 TRAMWAY RD SANFORD, NC 27330-	0	0	12/01/2017	CURTIS BARNETT ELECTRICAL	(910) 875-3097	EMTRAV PROPERTIES LL	City of Sanford	
ELEC-12-17-29914	225 WEATHERSPOON ST I SANFORD, NC 27330-	0	0	12/04/2017	P. R. FAULK ELECTRICAL CORP.	(919) 775-1990	CITY OF SANFORD	City of Sanford	
ELEC-12-17-29925	112 HILLCREST DR SANFORD, NC 27330-	0	0	12/06/2017	EDWIN JOHNSON LEE COUNTY	(919) 718-4622	LEE COUNTY	City of Sanford	
ELEC-12-17-29996	4300 OAK PARK RD SANFORD, NY 27330-	0	0	12/15/2017	SOUTHERN ELECTRIC & AUTOMATION CORP.	(919) 498-4122	PFIZER	Lee County	

ELEC-12-17-30000	1775 HAWKINS AVE SANFORD, NC 27330-	0	0	12/15/2017	STONER ELECT. CO., M.R.	919-774-8877	T L C HOME INC HOME IN	City of Sanford
ELEC-12-17-30021	4300 OAK PARK RD SANFORD, NC 27330-	0	0	12/18/2017	INSERV (INTEGRATED INDUSTRIAL SERVICES, IN	(919)552-6355	Pfizer	Lee County
ELEC-12-17-30030	1751 COLON RD SANFORD, NC 27331-	0	0	12/20/2017	SCOTT CARPENTER		LEE IRON & METAL COM	Lee County
ELEC-12-17-30048	1848 PICKETT RD SANFORD, NC 27330-	0	0	12/21/2017	REGGIE BROOKS WIRING	(843)414-9754	GROSS LAND COMPANY	Lee County
ELEC-12-17-30074	3997 NC 87 HWY S SANFORD, NC 27330-	0	0	12/27/2017	DAWSON ELECTRIC INC	(919)201-3841	ODELL THOMAS	Lee County
ELEC-12-17-30083	4127 JEFFERSON DAVIS H SANFORD, NC 27330-	0	0	12/28/2017	FACTION ELECTRIC LLC	(919)218-0951	POWELL BROTHERS LLC	Lee County
ELEC-12-17-30098	4300 OAK PARK RD SANFORD, NC 27330-	0	0	12/29/2017	INTEGRATED INDUSTRIAL SERVICES	(919)552-6355	PRAXIS BIOLOGICS INC	Lee County

MH Single-Wide

Permit #	Location	Sq. Ft.	Valuation	Issued	Contractor	Phone	Owner	District	HRF
ELEC-12-17-29907	235 WALK ABOUT LN SANFORD, NC 27330-	0	0	12/04/2017	RICHARDSON HEATING & AIR -CONDITIONING INC	(919)934-7754	BUCKHORN ESTATES LL	Lee County	
ELEC-12-17-29927	22 WILLOW CIR SANFORD, NC 27330-	0	0	12/06/2017	DEAN ELECTRIC	(919)770-2097	PINE VILLAGE MHC LLC	Lee County	
ELEC-12-17-29928	27 WILLOW CIR SANFORD, NC 27330-	0	0	12/06/2017	DEAN ELECTRIC	(919)770-2097	PINE VILLAGE MHC LLC	City of Sanford	
ELEC-12-17-29929	28 WILLOW LN SANFORD, NC 27330-	0	0	12/06/2017	DEAN ELECTRIC	(919)770-2097	PINE VILLAGE MHC LLC	City of Sanford	
ELEC-12-17-29931	91 EDIS LN SANFORD, NC 27330-	0	0	12/06/2017	WILLIAM HOUSTON	(919)776-1752	WILLIAM HOUSTON	Lee County	
ELEC-12-17-30003	2757 NICHOLSON RD SANFORD, NC 27330-	0	0	12/15/2017	JOEY HARDIN ELECTRICAL SERVICE	(910)740-6694	RODNEY WOOD	Lee County	
ELEC-12-17-30005	203 CHARLES RIDDLE RD SANFORD, NC 27330-	0	0	12/15/2017	MICHAEL RIDDLE	(919)721-4664	MICHAEL RIDDLE	Lee County	
ELEC-12-17-30072	1176 BLACKS CHAPEL RD SANFORD, NC 27330-	0	0	12/27/2017	T & G ELECTRIC OF SANFORD NC	919-499-2828	MELINDA EDWARDS	Lee County	
ELEC-12-17-30091	248 NOTTINGHAM LN SANFORD, NC 27330-	0	0	12/28/2017	JOEY HARDIN ELECTRICAL SERVICE	(910)740-6694	JOSHUA THOMPSON	Lee County	

Miscellaneous

Permit #	Location	Sq. Ft.	Valuation	Issued	Contractor	Phone	Owner	District	HRF
ELEC-12-17-29955	2894 COX MILL RD SANFORD, NC 27330-	0	0	12/04/2017	SOLSTICE ELECTRIC LLC	(919)538-7996	Herman Rosser	Lee County	
ELEC-12-17-29901	5815 QUAIL RIDGE DR SANFORD, NC 27330-	0	0	12/01/2017	WICKER ELECTRIC	(919)770-0472	ARTHUR MICHAEL DOWD	City of Sanford	
ELEC-12-17-29906	1104 LEMMOND DR SANFORD, NC 27330-	0	0	12/04/2017	P. R. FAULK ELECTRICAL CORP.	(919)775-1990	BOBBY BEARD	City of Sanford	
ELEC-12-17-29937	1583 KENTYREWOOD FAR SANFORD, NC 27330-	0	0	12/07/2017	J.M. POPE ELECTRIC LLC	(919)776-5144	ROSE BUD HOLDINGS LL	Lee County	
ELEC-12-17-30023	2101 NASH ST SANFORD, NC 27330-	0	0	12/19/2017	WST INDUSTRIES LLC	(919)775-2320	MAGNETTI MARELLI	City of Sanford	

Power Restoration

Permit #	Location	Sq. Ft.	Valuation	Issued	Contractor	Phone	Owner	District	HRF
ELEC-12-17-29912	703 CLEARWATER DR SANFORD, NC 27330-	0	0	12/04/2017	M & T ELECTRICAL CONTRACTORS INC.	(919)770-3548	WICKER-BATCHELOR RE	City of Sanford	
ELEC-12-17-29935	63 WILLMOUTH RD SANFORD, NC 27330-	0	0	12/06/2017	J.S. HOWARD ELECTRICAL	(919)774-1650	US BANK NATIONAL ASS	Lee County	
ELEC-12-17-29949	607 CLEARWATER DR SANFORD, NC 27330-	0	0	12/08/2017	M & T ELECTRICAL CONTRACTORS INC.	(919)770-3548	WICKER-BATCHELOR RE	Lee County	
ELEC-12-17-29961	33 OAK POINT LN SANFORD, NC 27330-	0	0	12/11/2017	REINALDO DIAZ	(240)506-1942	REINALDO DIAZ	Lee County	
ELEC-12-17-29963	503-B GREENSBORO AVE SANFORD, NC 27330-	0	0	12/11/2017	DEAN ELECTRIC	(919)770-2097	TIMOTHY S KNOWLES	City of Sanford	

Residential Addition

Permit #	Location	Sq. Ft.	Valuation	Issued	Contractor	Phone	Owner	District	HRF
ELEC-12-17-29897	714 SPRING LN SANFORD, NC 27330-	0	0	12/01/2017	DANNY COX	(919)770-9423	REBECCA WATSON	City of Sanford	
ELEC-12-17-30076	1317 GORMLY CIR SANFORD, NC 27330-	0	0	12/27/2017	DOUGLAS ELECTRIC, INC	(919) 499-6900	ELIZABETH SMITH	City of Sanford	

Residential New

Permit #	Location	Sq. Ft.	Valuation	Issued	Contractor	Phone	Owner	District	HRF

ELEC-12-17-29934	421 REYNWOOD VISTA SANFORD, NC 27330-	0	0	12/06/2017	PEDRO ELECTRIC	(919)954-1252	SUNIL P & VIDYA PERSA	Lee County
ELEC-12-17-29988	8017 ROYAL DR SANFORD, NC 27330-	0	0	12/14/2017	accelarated services inc.	(919)718-1156	ISREAL LUCAS	Lee County
ELEC-12-17-30059	413 CASTLEBERRY RD Sanford, NC 27332-	0	0	12/21/2017	PIONEER ELECTRIC AND MAINTENANCE COMPAN	(919) 499-7767	PRESTON PERDUE	Lee County
ELEC-12-17-30077	4792 COX MILL RD SANFORD, NC 27332-	0	0	12/27/2017	DOUGLAS ELECTRIC, INC	(919) 499-6900	JOHN FERGUSON	Lee County
ELEC-12-17-30079	1477 ABERCORN LN SANFORD, NC 27330-	0	0	12/28/2017	CMC ELECTRIC LLC	(919)291-0989	SMITH DOUGLAS HOMES	City of Sanford
ELEC-12-17-30087	4660 FARRELL RD SANFORD, NC 27330-	0	0	12/28/2017	T.B. BRIGGS ELECTRICAL SERVICE	(910)585-0260	VICKY L EPPS & DENNIS	Lee County
ELEC-12-17-30096	126 MILL RUN LN Sanford, NC 27330-	0	0	12/29/2017	BILLINGS ELECTRIC CO, INC	(919) 258-3115	CUSTOM CONTRACTING	Lee County

Residential Renovation

Permit #	Location	Sq. Ft.	Valuation	Issued	Contractor	Phone	Owner	District	HRF
ELEC-12-17-29911	2167 HICKORY HOUSE RD SANFORD, NC 27330-	0	0	12/04/2017	DOUGLAS ELECTRIC, INC.	(919) 708-8936	DONALD BULLARD	Lee County	
ELEC-12-17-29976	508 GREENSBORO AVE SANFORD, NC 27330-	0	0	12/13/2017	C-TECH CONTRACTORS LLC	(910)229-8461	SOBHI ALOWDI	City of Sanford	
ELEC-12-17-29980	209 CURRIE DR S SANFORD, NC 27330-	0	0	12/14/2017	SOLSTICE ELECTRIC LLC	(919)538-7996	EDWIN BRUNER	City of Sanford	
ELEC-12-17-29987	3113 WILD FOREST RD SANFORD, NC 27330-	0	0	12/14/2017	WICKER ELECTRIC	(919)770-0472	TONY WILLIAMS	Lee County	

Service Change

Permit #	Location	Sq. Ft.	Valuation	Issued	Contractor	Phone	Owner	District	HRF
ELEC-12-17-29902	1901 TRUMAN DR SANFORD, NC 27330-	0	0	12/01/2017	WICKER ELECTRIC	(919)770-0472	ALEXANDER JOSIAH MEL	City of Sanford	
ELEC-12-17-29939	1409 RAY AVE SANFORD, NC 27330-	0	0	12/07/2017	W.G. ELECTRICAL SERVICES	(336)599-6905	CARLOS BARAHONA	City of Sanford	
ELEC-12-17-29954	2413 CARBONTON RD SANFORD, NC 27330-	0	0	12/08/2017	T & G ELECTRIC OF SANFORD NC	919-499-2828	WILLIAM U WORNOM	City of Sanford	
ELEC-12-17-29973	109 THIRD ST S SANFORD, NC 27330-	0	0	12/12/2017	C & K ELECT & PLUMBING COMPANY	919-776-2044	LEE COUNTY AND CITY O	City of Sanford	

ELEC-12-17-29975	141 NEIL BLUE LN SANFORD, NC 27332-	0	0	12/13/2017	STONER ELECT. CO., M.R.	919-774-8877	LILLIE MAE MONROE	Lee County
ELEC-12-17-30011	107 ELLIOTT RD SANFORD, NC 27332-	0	0	12/18/2017	RICKY YARBOROUGH	(919)770-4078	CARL D ICEMAN	Lee County
ELEC-12-17-30019	1001 HAWKINS AVE SANFORD, NC 27330-	0	0	12/18/2017	FACTION ELECTRIC LLC	(919)218-0951	STAVROS GUSTOS	City of Sanford
ELEC-12-17-30045	533 OAKLEAF RD SANFORD, NC 27330-	0	0	12/21/2017	BITTING ELECTRIC INC	(919)467-9417	WILLIAM H THOMAS	Lee County
ELEC-12-17-30049	123 BUFFALO ST E SANFORD, NC 27330-	0	0	12/21/2017	G.E.B. ELECTRICAL	(919)499-6013	JOHN IVAN GUNTER	City of Sanford
ELEC-12-17-30060	378 PYRANT RD SANFORD, NC 27332-	0	0	12/22/2017	SANFORD ELECTRICAL CONTRACTORS	(919)356-9628	MARILYN CHANDLER	Lee County

Swimming Pool

Permit #	Location	Sq. Ft.	Valuation	Issued	Contractor	Phone	Owner	District	HRF
ELEC-12-17-29943	2629 BRISTOL WAY SANFORD, NC 27330-	0	0	12/07/2017	HARTE POOL WIRING AND LIGHTING INC.	(919)868-8195	BRAD HUNTER	City of Sanford	

Temporary Service Pole

Permit #	Location	Sq. Ft.	Valuation	Issued	Contractor	Phone	Owner	District	HRF
ELEC-12-17-29932	2301 BROWN RD SANFORD, NC 27330-	0	0	12/06/2017	CLAY MORETZ	(919)770-4858	C P PROPERTIES INC	Lee County	

Number of Electrical Permit: 62

Valuation Total: \$0.00

Permits Monthly Report
From 12/1/2017 To 12/31/2017

Malt Beverage Application
BO-1-1-D
<NONE>

Permit #	Location	Sq. Ft.	Valuation	Issued	Contractor	Phone	Owner	District	HRF
MAL-T-12-17-30092	3207 LEE AVE SANFORD, NC 27330-	0	0	12/29/2017	GANG N YOO	(919)412-7749	HANKOOK REALTY LLC	City of Sanford	
MAL-T-12-17-30097	2045 HORNER BLVD S SANFORD, NC 27331-	0	0	12/29/2017	RITE AID	(919)776-3766	RITE AID PHARM	City of Sanford	
MAL-T-12-17-30101	1135 SPRING LN SANFORD, NC 27330-	0	0	12/29/2017	RITE AID	(919)776-3766	GENESIS 2007 PROPERT	City of Sanford	

Number of Malt Beverage Application: 3

Valuation Total: \$0.00

Permits Monthly Report
 From 12/1/2017 To 12/31/2017

Manufactured Home Setup Permit
MH Single-Wide

Permit #	Location	Sq. Ft.	Valuation	Issued	Contractor	Phone	Owner	District	HRF
MANU-12-17-29920	91 ED'S LN SANFORD, NC 27330-	0	0	12/05/2017	RAVEN ROCK M.H. MOVERS	919-775-3600	WILLIAM HOUSTON	Lee County	
MANU-12-17-29956	203 CHARLES RIDDLER RD SANFORD, NC 27330-	0	0	12/08/2017	RODNEY BROWN	(919)356-4773	MICHAEL RIDDLER	Lee County	
MANU-12-17-30036	LOT 1 ST ANDREWS CHUF SANFORD, NC 27330-	0	0	12/20/2017	RODNEY BROWN	(919)356-4773	JAMES TUCKER	ETJ	
MANU-12-17-30062	1176 BLACKS CHAPEL RD SANFORD, NC 27330-	0	0	12/22/2017	MELINDA EDWARDS	(910)890-6800	MELINDA EDWARDS	Lee County	

Number of Manufactured Home Setup Permits: 4

Valuation Total: \$0.00

Permits Monthly Report
From 12/1/2017 To 12/31/2017

Agenda
8
2018
00055

MECHANICAL PERMIT
Comm Ductwork Addition

Permit #	Location	Sq. Ft.	Valuation	Issued	Contractor	Phone	Owner	District	HRF
MECH-12-17-29947	1508 TRAMWAY RD SANFORD, NC 27330-	0	0	12/21/2017	RELIABLE HEAT & AIR	(910)624-9162	EMTRAV PROPERTIES LL	City of Sanford	

Commercial

Permit #	Location	Sq. Ft.	Valuation	Issued	Contractor	Phone	Owner	District	HRF
MECH-12-17-29908	1409 GREENWAY CT SANFORD, NC 27330-	0	0	12/04/2017	FOUR SEASONS HEATING AND A/C	(910)235-0606	PINEHURST MEDICAL GR	City of Sanford	
MECH-12-17-29919	4127 JEFFERSON DAVIS H SANFORD, NC 27330-	0	0	12/05/2017	CENTER HEATING & AIR	919-775-2500	POWELL BROTHERS LLC	Lee County	
MECH-12-17-29926	1420 BRAGG ST SANFORD, NC 27330-	0	0	12/06/2017	SURETEMP MECHANICAL	919-770-4120	LEE COUNTY	City of Sanford	
MECH-12-17-29945	1503 ELM ST SANFORD, NC 27330-	0	0	12/07/2017	RICKY YARBOROUGH	(919)770-4078	LEE COUNTY LEE COUN	City of Sanford	
MECH-12-17-30018	4300 OAK PARK RD SANFORD, NC 27330-	0	0	12/18/2017	INTERGRATED INDUSTRIAL SERVICES, INC/DBA:	(919) 562-6355	PFIZER	Lee County	
MECH-12-17-30035	2101 NASH ST SANFORD, NC 27330-	0	0	12/20/2017	QUALITY COMFORT SERVICES, INC	(919)217-5640	MAGNETTI MARELLI	City of Sanford	

Residential

Permit #	Location	Sq. Ft.	Valuation	Issued	Contractor	Phone	Owner	District	HRF
MECH-11-17-29885	2757 NICHOLSON RD SANFORD, NC 27330-	0	0	12/01/2017	SWAIM ELECTRIC	(336)685-9722	RODNEY WOOD	Lee County	
MECH-11-17-29892	450 CEDAR LANE RD SANFORD, NC 27332-	0	0	12/01/2017	COMFORT FIRST HEATING & COOLING, INC	919 777-1777	DAVID A KIRBY	Lee County	
MECH-11-17-29893	1411 PINEHURST ST SANFORD, NC 27330-	0	0	12/01/2017	HUNEYCUTT MECHANICAL, INC.	(704)779-8900	BENITA RUTH JONES	City of Sanford	
MECH-12-17-29895	2801 CENTER CHURCH RE SANFORD, NC 27330-	0	0	12/01/2017	JOYNER & DICKENS H & A/C, INC.	919-774-6841	CHARLES M COFFER	Lee County	

MECH-12-17-29898	204 ACORN DR SANFORD, NC 27330-	0	12/01/2017	SERVICES UNLIMITED	(910)978-4490	CHARLES E LOCKAMY	City of Sanford
MECH-12-17-29910	18 THOMAS KELLY RD SANFORD, NC 27330-	0	12/07/2017	COMFORT FIRST HEATING & COOLING, INC	919 777-1777	JULIAN W THOMAS	Lee County
MECH-12-17-29913	1743 DAQUIRI TURN SANFORD, NC 27330-	0	12/07/2017	COMFORT FIRST	(919)935-9642	ROBERT T & JAN H CARL	Lee County
MECH-12-17-29915	503 OLDE TOWNE DR SANFORD, NC 27330-	0	12/04/2017	72 DEGREES HEATING AND AIR	(919)777-2777	JOHN HOWARD	City of Sanford
MECH-12-17-29916	414 COURTLAND DR SANFORD, NC 27330-	0	12/04/2017	D & H HVAC INC.	(919)628-2183	DORIS MCLEOD	City of Sanford
MECH-12-17-29917	620 CHISHOLM ST W SANFORD, NC 27330-	0	12/05/2017	JOYNER & DICKENS H & A/C, INC.	919-774-6841	EMILY G/TRUSTEE EASO	City of Sanford
MECH-12-17-29918	2167 HICKORY HOUSE RD SANFORD, NC 27330-	0	12/05/2017	DONALD BULLARD	(919)353-0203	DONALD BULLARD	Lee County
MECH-12-17-29921	1317 GORMLY CIR SANFORD, NC 27330-	0	12/05/2017	NORTH CAROLINA FIREPLACE CO., INC.	(919)774-1440	ELIZABETH SMITH	City of Sanford
MECH-12-17-29922	1697 PICKARD RD SANFORD, NC 27330-	0	12/05/2017	NORTH CAROLINA FIREPLACE CO., INC.	(919)774-1440	DAVID DUSENBURY	Lee County
MECH-12-17-29923	212 GLENDALE CIR SANFORD, NC 27330-	0	12/05/2017	NORTH CAROLINA FIREPLACE CO., INC.	(919)774-1440	RONALD MCCLOSKEY	Lee County
MECH-12-17-29924	4870 CENTER CHURCH RT SANFORD, NC 27330-	0	12/05/2017	SURETEMP MECHANICAL	919-770-4120	BRENDON WINDMEYER	Lee County
MECH-12-17-29933	1302 RAY AVE SANFORD, NC 27330-	0	12/06/2017	TIN SHOP	(919)499-1759	G&L HORIZON PROPERT	City of Sanford
MECH-12-17-29936	1313 TRAMWAY RD SANFORD, NC 27332-	0	12/07/2017	FARMER LP GAS & OIL CO., INC.	(910)893-3598	LORI T TILLET	ETJ
MECH-12-17-29942	409 DUDLEY AVE SANFORD, NC 27330-	0	12/07/2017	ARS	(919)865-7777	IRENE W MCDONALD	City of Sanford
MECH-12-17-29947	1808 CHEROKEE TR SANFORD, NC 27332-	0	12/08/2017	ROY FRANKLIN MILLS III	(919)935-9433	CHAD THOMAS ASHWOR	City of Sanford
MECH-12-17-29964	91 EDS LN SANFORD, NC 27330-	0	12/11/2017	TIN SHOP	(919)499-1759	WILLIAM HOUSTON	Lee County
MECH-12-17-29970	1826 IRISH BLVD SANFORD, NC 27332-	0	12/12/2017	COMFORT FIRST HEATING & COOLING, INC	919 777-1777	ARLENE GILBERT	Lee County
MECH-12-17-29971	3707 WICKER ST SANFORD, NC 27330-	0	12/12/2017	JOYNER & DICKENS H & A/C, INC.	919-774-6841	BETTY O MCLEOD	Lee County

MECH-12-17-29982	508 GREENSBORO AVE SANFORD, NC 27330-	0	12/13/2017	GOINS HEATING & COOLING	(910)843-1220	SOBHI ALLOWDI	City of Sanford
MECH-12-17-29983	1801 CARBONTON RD SANFORD, NC 27330-	0	12/13/2017	JOYNER & DICKENS	(919)774-6841	STEPHEN W HUDZIK	City of Sanford
MECH-12-17-29986	4792 COX MILL RD SANFORD, NC 27332-	0	12/14/2017	D & H HVAC INC.	(919)628-2183	JOHN FERGUSON	Lee County
MECH-12-17-29991	208 WICKFIELD DR SANFORD, NC 27330-	0	12/15/2017	JOYNER & DICKENS H & A/C, INC.	919-774-6841	JOHN M CAMERON	City of Sanford
MECH-12-17-29993	979 HIGH HARBOR SANFORD, NC 27332-	0	12/15/2017	72 DEGREES HEATING AND AIR	(919)777-2777	LORETTA WEMMER	Lee County
MECH-12-17-30006	203 CHARLES RIDDLER RD SANFORD, NC 27330-	0	12/15/2017	MICHAEL RIDDLER	(919)721-4664	MICHAEL RIDDLER	Lee County
MECH-12-17-30009	7228 KINGFISHER DR SANFORD, NC 27330-	0	12/18/2017	JOYNER & DICKENS H & A/C, INC.	919-774-6841	GEORGE PATRICK FIELD	Lee County
MECH-12-17-30010	151 ZION CHURCH RD SANFORD, NC 27330-	0	12/18/2017	RICKY YARBOROUGH	(919)770-4078	TIMOTHY WAYNE	Lee County
MECH-12-17-30014	538 PERTH DR SANFORD, NC 27330-	0	12/20/2017	COMFORT FIRST	(919)935-9642	DALE A & CAROL A ABBE	Lee County
MECH-12-17-30016	216 MAPLE AVE SANFORD, NC 27330-	0	12/18/2017	TIN SHOP	(919)499-1759	EXODUS REALTY LLC	City of Sanford
MECH-12-17-30024	5308 TIMBER RIDGE DR SANFORD, NC 27330-	0	12/19/2017	JOYNER & DICKENS H & A/C, INC.	919-774-6841	EMT 44 LLC	City of Sanford
MECH-12-17-30025	951 STEEL BRIDGE RD SANFORD, NC 27330-	0	12/19/2017	JOYNER & DICKENS H & A/C, INC.	919-774-6841	HAROLD CAMERON	Lee County
MECH-12-17-30027	8017 ROYAL DR SANFORD, NC 27330-	0	12/19/2017	ISRAEL LUCAS	(919)770-0902	ISREAL LUCAS	Lee County
MECH-12-17-30029	2032 LONG POINT TR SANFORD, NC 27332-	0	12/20/2017	JOYNER & DICKENS H & A/C, INC.	919-774-6841	FLORENCE J (KAISEN	Lee County
MECH-12-17-30031	1317 GORMLEY CIR SANFORD, NC 27330-	0	12/20/2017	FOUR SEASON HEATING & AIR	(910) 235-0606	ELIZABETH SMITH	City of Sanford
MECH-12-17-30032	1814 CARBONTON RD SANFORD, NC 27330-	0	12/20/2017	CENTER HEATING & AIR	919-775-2500	ROSEMARY M PARTEN	City of Sanford
MECH-12-17-30038	3206 SMOKEY PATH SANFORD, NC 27330-	0	12/20/2017	SWAIM ELECTRICAL HEAT & AIR, INC	(336) 685-9722	JOHN KIRKMAN	Lee County
MECH-12-17-30039	248 NOTTINGHAM LN SANFORD, NC 27330-	0	12/20/2017	SWAIM ELECTRICAL HEAT & AIR, INC	(336) 685-9722	JOSHUA THOMPSON	Lee County

MECH-12-17-30040	88 EAKER DR CAMERON, NC 28326-	0	12/20/2017	CAROLINA COMFORT AIR INC.	(919)934-1060	HERMAN MCDOWELL	Lee County
MECH-12-17-30041	94 EAKER DR CAMERON, NC 28326-	0	12/20/2017	CAROLINA COMFORT AIR INC.	(919)934-1060	HERMAN MCDOWELL	Lee County
MECH-12-17-30042	90 EAKER DR CAMERON, NC 28326-	0	12/20/2017	CAROLINA COMFORT AIR INC.	(919)934-1060	HERMAN MCDOWELL	Lee County
MECH-12-17-30043	1506 COLUMBINE RD SANFORD, NC 27330-	0	12/21/2017	JOYNER & DICKENS H & A/C, INC.	919-774-6841	WILLIAM H RICHARDSON	City of Sanford
MECH-12-17-30051	1484 ABERCORN LN SANFORD, NC 27330-	0	12/21/2017	COOPER CONTRACTORS	(919)353-0897	SMITH DOUGLAS HOMES	City of Sanford
MECH-12-17-30052	119 MILL RUN LN Sanford, NC 27330-	0	12/21/2017	COOPER CONTRACTORS	(919)353-0897	SMITH DOUGLAS HOMES	Lee County
MECH-12-17-30061	204 CHARIOT DR SANFORD, NC 27330-	0	12/22/2017	COMFORT FIRST HEATING & COOLING, INC	919 777-1777	CLINTON C PICKARD	City of Sanford
MECH-12-17-30071	235 WALK ABOUT LN SANFORD, NC 27330-	0	12/27/2017	MELVIN RUTLEDGE	(919)669-8757	BUCKHORN ESTATES LL	Lee County
MECH-12-17-30073	105 JOHNSON ST SANFORD, NC 27505-	0	12/27/2017	SERVICES UNLIMITED	(910)978-4490	TERI PARRISH SPIVEY	Town of Broadway
MECH-12-17-30075	1317 GORMLY CIR SANFORD, NC 27330-	0	12/27/2017	JEFFREY ERIC BARRINGTON	(910)331-0818	ELIZABETH SMITH	City of Sanford
MECH-12-17-30078	4031 GREY FOX CT SANFORD, NC 27330-	0	12/27/2017	72 DEGREES HEATING AND AIR	(919)777-2777	KENNETH & SHARON K R	Lee County
MECH-12-17-30082	425 CEDAR RIDGE LN SANFORD, NC 27330-	0	12/28/2017	CAROLINA COMFORT AIR INC.	(919)934-1060	JUSTIN MICHAEL HARRIN	Lee County
MECH-12-17-30084	108 SUNRISE DR SANFORD, NC 27330-	0	12/28/2017	MARGARET CERSOSIMO	(828)896-5672	MARGARET CERSOSIMO	Lee County
MECH-12-17-30085	2784 CHRIS COLE RD SANFORD, NC 27330-	0	12/28/2017	JOYNER & DICKENS H & A/C, INC.	919-774-6841	WAYNE BULLARD	Lee County
MECH-12-17-30086	1802 COOL SPRINGS RD SANFORD, NC 27330-	0	12/28/2017	JOYNER & DICKENS H & A/C, INC.	919-774-6841	MARY ALICE/TRUSTEE H	City of Sanford

Number of Mechanical Permit: 62

Valuation Total: \$0.00

Permits Monthly Report
From 12/1/2017 To 12/31/2017

Plumbing Permit
Commercial

Permit #	Location	Sq. Ft.	Valuation	Issued	Contractor	Phone	Owner	District	HRF
PLUM-11-17-29785	542 RYDER LAKES DR SANFORD, NC 27330-	0	0	12/28/2017	SIMPSON PLUMBING	(910)690-3831	LAKE SIDE TOWNHOMES	City of Sanford	
PLUM-11-17-29786	544 RYDER LAKES DR SANFORD, NC 27330-	0	0	12/28/2017	SIMPSON PLUMBING	(910)690-3831	LAKE SIDE TOWNHOMES	City of Sanford	
PLUM-11-17-29799	546 RYDER LAKES DR SANFORD, NC 27330-	0	0	12/28/2017	SIMPSON PLUMBING	(910)690-3831	LAKE SIDE TOWNHOMES	City of Sanford	
PLUM-11-17-29801	548 RYDER LAKES DR SANFORD, NC 27330-	0	0	12/28/2017	SIMPSON PLUMBING	(910)690-3831	LAKE SIDE TOWNHOMES	City of Sanford	
PLUM-12-17-29948	3997 NC 87 HWY S SANFORD, NC 27330-	0	0	12/08/2017	PIPEWORX PLUMBING, INC.	(919)770-6452	ODELL THOMAS	Lee County	
PLUM-12-17-30020	4300 OAK PARK RD SANFORD, NC 27330-	0	0	12/18/2017	INSERT INTEGRATED INDUSTRIAL SERVICES, IN	(919)552-6355	PFIZER	Lee County	
PLUM-12-17-30046	317 STEELE ST SANFORD, NC 27330-	0	0	12/21/2017	STATEN PLUMBING, INC	(919)483-6578	LAWRENCE CURTIS	City of Sanford	

MH Single-Wide

Permit #	Location	Sq. Ft.	Valuation	Issued	Contractor	Phone	Owner	District	HRF
PLUM-12-17-29930	91 ED'S LN SANFORD, NC 27330-	0	0	12/06/2017	WILLIAM HOUSTON	(919)776-1752	WILLIAM HOUSTON	Lee County	
PLUM-12-17-29938	235 WALK ABOUT LN SANFORD, NC 27330-	0	0	12/07/2017	MELVIN RUTLEDGE	(919)669-8757	BUCKHORN ESTATES LL	Lee County	
PLUM-12-17-29950	248 NOTTINGHAM LN SANFORD, NC 27330-	0	0	12/08/2017	A & M CONTRACTORS, INC.	(910)652-6230	JOSHUA THOMPSON	Lee County	
PLUM-12-17-29981	939 MCPHERSON RD SANFORD, NC 27330-	0	0	12/13/2017	RONALD MCLYMORE	(919)258-9788	MARY ROLLINS	Lee County	
PLUM-12-17-30004	203 CHARLES RIDDLER RD SANFORD, NC 27330-	0	0	12/15/2017	MICHAEL RIDDLER	(919)721-4664	MICHAEL RIDDLER	Lee County	

PLUM-12-17-30063 1176 BLACKS CHAPEL RD 0 12/22/2017 MELINDA EDWARDS (910)890-6800 MELINDA EDWARDS Lee County

Modular Home

PLUM-12-17-30060 3206 SMOKEY PATH 0 12/14/2017 A & M CONTRACTORS, INC. (919)652-6230 JOHN KIRKMAN Lee County

Other

PLUM-12-17-29974 1037 SAN-LEE DR 0 12/12/2017 EARLISE JONES PLUMBING CO. (910)484-9403 PASTOR BENNIE BRYAN ETJ

PLUM-12-17-30013 8092 SHERIFF WATSON RD 0 12/18/2017 ELIZA MARTINEZ JARDON (919)782-7599 CHARLOTTE HOHENSTE Lee County

PLUM-12-17-30022 3032 BRANDY LN 0 12/18/2017 REBATH OF THE TRIANGLE (919)774-3042 JOHN E SCHRULL City of Sanford

PLUM-12-17-30026 303 BRIDGEWATER DR 0 12/19/2017 PHOENIX FIRE PROTECTION (919)770-0168 MERMON DOUGLAS Lee County

Residential Addition

PLUM-12-17-29941 714 SPRING LN 0 12/07/2017 HIGHLANDER PLUMBING, LLC (919)837-5443 REBECCA WATSON City of Sanford

PLUM-12-17-30034 1317 GORMLY CIR 0 12/20/2017 RELIABLE PLUMBING, INC. (919)775-5782 ELIZABETH SMITH City of Sanford

Residential Alteration

PLUM-12-17-30094 982 PENDERGRASS RD 0 12/29/2017 FIX-IT PLUMBING (919)776-7870 LYNN DEE BARKER CAR Lee County

Residential New

PLUM-12-17-29909 102 CROSBY LN 0 12/04/2017 MICHAEL LESLIE PLUMBING (919)499-8874 BRANDON HARRINGTON Lee County

PLUM-12-17-29959	1905 WINDMILL DR SANFORD, NC 27330-	0	0	12/11/2017	NEAL & HOWARD, INC.	(919)775-3811	CHUCK MANNES	City of Sanford
PLUM-12-17-29972	421 REYNWOOD VISTA SANFORD, NC 27330-	0	0	12/12/2017	WHITES PLUMBING LLC	(919)435-0736	SUNIL P & VIDYA PERSA	Lee County
PLUM-12-17-30028	1477 ABERCORN LN SANFORD, NC 27330-	0	0	12/19/2017	CELEY'S QUALITY SERVICES, LLC	(919)938-1813	SMITH DOUGLAS HOMES	City of Sanford
PLUM-12-17-30037	909 BURGESS CIR BROADWAY, NC 27505-	0	0	12/20/2017	DOUBLE J PLUMBING LLC	(910)814-7705	STEVE THOMAS	Town of Broadway
PLUM-12-17-30053	8017 ROYAL DR SANFORD, NC 27330-	0	0	12/21/2017	COX BROTHERS PLUMBING	(919) 258-9559	ISREAL LUCAS	Lee County
PLUM-12-17-30054	8018 ROYAL DR SANFORD, NC 27330-	0	0	12/21/2017	COX BROTHERS PLUMBING	(919) 258-9559	ISREAL LUCAS	Lee County

Residential Renovation

Permit #	Location	Sq. Ft.	Valuation	Issued	Contractor	Phone	Owner	District	HRF
PLUM-12-17-29960	1800 COOL SPRINGS RD SANFORD, NC 27330-	0	0	12/11/2017	NEAL & HOWARD, INC.	(919)775-3811	MARY HOLMES	City of Sanford	

Number of Plumbing Permits: 30

Valuation Total: \$0.00

Permits Monthly Report
From 12/11/2017 To 12/31/2017

Residential Building Permit
B-1-D

Accessory Building

Permit #	Location	Sq. Ft.	Valuation	Issued	Contractor	Phone	Owner	District	HRF
RES-11-17-29851	900 GILMORE DR SANFORD, NC 27330-	1024	40960	12/01/2017	TATUM BUILDERS, INC	(919)690-4197	MICHAEL TATUM	City of Sanford	
RES-12-17-29962	216 CIRCLE AVE SANFORD, NC 27330-	192	7680	12/19/2017	FELIPA CORDOVA	(919)842-6262	FELIPA CORDOVA	City of Sanford	
RES-12-17-30044	957 CUMNOCK RD SANFORD, NC 27330-	600	48000	12/21/2017	DEBORAH HALL & KEVIN DEGON	(919)775-7506	DEBORAH HALL & KEVIN	Lee County	
RES-12-17-30056	515 GOVERNORS CREEK I SANFORD, NC 27330-	2112	84480	12/27/2017	CAROLINA CUSTOM BUILDERS	(919)790-1234	CHRISTOPHER RORER	Lee County	

Addition

Permit #	Location	Sq. Ft.	Valuation	Issued	Contractor	Phone	Owner	District	HRF
RES-12-17-29896	791 CASHMERE CT SANFORD, NC 27330-	300	7500	12/01/2017	R & E CONSTRUCTION	(919)356-9933	EDNA STEPHENSON	Lee County	
RES-12-17-29944	515 GARDEN ST W SANFORD, NC 27330-	868	58825	12/11/2017	JUAN PABLO JORGE RIVERA	(919)600-1448	JUAN PABLO JORGE RIV	City of Sanford	

Modular Home

Permit #	Location	Sq. Ft.	Valuation	Issued	Contractor	Phone	Owner	District	HRF
RES-12-17-29998	130 HARDWOOD LN SANFORD, NC 27330-	3532	227980	12/19/2017	TCC VANDERBUILT	(919)718-2760	ROBERT & JENNIFER FOX	Lee County	
RES-12-17-30008	3370 CARBANTON RD SANFORD, NC 27330-	1797	141120	12/20/2017	NORTH CAROLINA CUSTOM MODULAR	(336)610-5150	BRANDON HILL	Lee County	

New

Permit #	Location	Sq. Ft.	Valuation	Issued	Contractor	Phone	Owner	District	HRF
RES-10-17-29375	741 BRIDGES RD SANFORD, NC 27330-	2174	173920	12/04/2017	P.L. CONSTRUCTION LLC	(919)356-4045	BRYAN LANCASTER II	Lee County	Yes

RES-12-17-29904	186 TRIPLE FARM LN SANFORD, NC 27330-	2482	180150	12/04/2017	CAROLINA BUILDERS GROUP	(910)973-8354	EDUARDO LEMUS	Lee County	Yes
RES-12-17-29905	909 BURGESS CIR BROADWAY, NC 27505-	2490	155630	12/19/2017	STEVE THOMAS	(919)906-4069	STEVE THOMAS	Town of Broadway	Yes
RES-12-17-29955	2003 SPRING LN SANFORD, NC 27330-	2214	150390	12/12/2017	SMITH RESIDENTIAL BUILDER LLC	(919) 353-0412	TOMMY SMITH	City of Sanford	Yes
RES-12-17-29966	123 MILL RUN LN Sanford, NC 27330-	4443	264020	12/14/2017	SMITH DOUGLAS HOMES	(919)800-9169	SMITH DOUGLAS HOMES	Lee County	Yes
RES-12-17-29967	3403 COTTEN RD SANFORD, NC 27330-	3490	208568.5	12/16/2017	STEVE SEAGROVES CONSTRUCTION	(919)775-9134	DOUGLAS DEGON	Lee County	Yes
RES-12-17-29999	1477 ABERCORN LN SANFORD, NC 27330-	2248	157180	12/19/2017	SMITH DOUGLAS HOMES	(919)800-9169	SMITH DOUGLAS HOMES	City of Sanford	Yes
RES-12-17-30001	112 CROSBY LN SANFORD, NC 27330-	3635	234960	12/19/2017	HARRINGTON PROPERTIES OF NC, LLC	(919)770-5869	BRANDON HARRINGTON	Lee County	Yes
RES-12-17-30058	7060 OAK RD SANFORD, NC 27332-	1840	147200	12/29/2017	CUSTOM CONTRACTING	(919)775-1497	CUSTOM CONTRACTING	Lee County	Yes

Renovation

Permit #	Location	Sq. Ft.	Valuation	Issued	Contractor	Phone	Owner	District	HRF
RES-11-17-29821	1209 WINTERLOCKEN DR SANFORD, NC 27330-	0	0	12/06/2017	FS, LLC DBA RAMJACK	(919)309-9727	MARC PAUDO	City of Sanford	
RES-11-17-29854	2894 COX MILL RD SANFORD, NC 27330-	0	0	12/04/2017	SOLSTICE ELECTRIC LLC	(919)538-7996	Herman Rosser	Lee County	
RES-12-17-29899	201 PLANK RD S SANFORD, NC 27330-	0	0	12/05/2017	ABC RESTORATION LLC	(919)478-7622	LARRY SAUNDERS	Lee County	
RES-12-17-29957	3113 WILD FOREST RD SANFORD, NC 27330-	0	0	12/13/2017	WSC PRECISION BUILDERS INC.	(919)770-6452	TONY WILLIAMS	Lee County	
RES-12-17-29979	209 CURRIE DR S SANFORD, NC 27330-	0	0	12/14/2017	SOLSTICE ELECTRIC LLC	(919)538-7996	EDWIN BRUNER	City of Sanford	
RES-12-17-30002	1719 PHILLIPS DR SANFORD, NC 27330-	0	0	12/20/2017	J. BRENT SMITH CONSTRUCTION	(919)775-9714	MARION PATE	City of Sanford	
RES-12-17-30057	505 BOULDERBROOK PAR SANFORD, NC 27330-	909	72720	12/27/2017	TINGEN CONSTRUCTION COMPANY	(919)422-2576	TINGEN CONSTRUCTION	City of Sanford	

Repair

Permit #	Location	Sq. Ft.	Valuation	Issued	Contractor	Phone	Owner	District	HRF
----------	----------	---------	-----------	--------	------------	-------	-------	----------	-----

BOC Agend
1-16-2018
PG 000064

Number of Residential Building Permit: 25

Valuation Total: \$2,361,283.50

RES-12-17-29900 529 BRACKEN ST 0 0 12/05/2017 SANTIAGO GARCIA (919)842-8726 SANTIAGO GARCIA Lee County

Permits Monthly Report
 From 12/1/2017 To 12/31/2017

Sign Permit
 BO 11-000065
 New

Permit #	Location	Sq. Ft.	Valuation	Issued	Contractor	Phone	Owner	District	HRF
SIGN-12-17-29953	1911 BRAGG ST SANFORD, NC 27330-	0	0	12/12/2017	CAROLINA SIGNS AND SERVICE	(919)639-3475	DEAN REAL ESTATE INC	City of Sanford	
SIGN-12-17-29958	3690 HIGHWAY 87 S SANFORD, NC 27330-	0	0	12/18/2017	YOUR SIGNS ON TIME	(336)601-2469	JT PROPERTIES OF NC L	City of Sanford	
SIGN-12-17-29977	2230 JEFFERSON DAVIS H SANFORD, NC 27330-	0	0	12/13/2017	919 ELECTRIC INC.	(919)602-5110	TRAMWAY STATION LLC	City of Sanford	

Number of Sign Permit: 3

Valuation Total: \$0.00

Permits Monthly Report
From 12/1/2017 To 12/31/2017

Sprinkler Permit

Miscellaneous

Permit #	Location	Sq. Ft.	Valuation	Issued	Contractor	Phone	Owner	District	HRF
SPRK-12-17-29952	0 COMMERCE DR SANFORD, NC 27330-	0	0	12/08/2017	VAN GROCE	(919)770-4883	VAN GROCE, SR.	Santord Fire/SPRK	
SPRK-12-17-30093	3207 LEE AVE SANFORD, NC 27330-	0	0	12/29/2017	GANG N YOO	(919)412-7749	HANKOOK REALTY LLC	Santord Fire/SPRK	
SPRK-12-17-30099	2045 HORNERS BLVD S SANFORD, NC 27331-	0	0	12/29/2017	RITE AID	(919)776-3766	RITE AID PHARM	Santord Fire/SPRK	
SPRK-12-17-30102	1135 SPRING LN SANFORD, NC 27330-	0	0	12/29/2017	RITE AID	(919)776-3766	GENESIS 2007 PROPERT	Santord Fire/SPRK	

New

Permit #	Location	Sq. Ft.	Valuation	Issued	Contractor	Phone	Owner	District	HRF
SPRK-12-17-29940	115 CHATHAM ST SANFORD, NC 27330-	0	0	12/07/2017	SENTRY FIRE PROTECTION CO. INC.	(336)625-2304	SANFORD BUGGY BUILD	Santord Fire/SPRK	
SPRK-12-17-29968	2919 BEECHTREE DR SANFORD, NC 27330-	0	0	12/12/2017	ASSOCIATED FIRE PROTECTION, INC.	(919)553-4021	FIRSTHEALTH OF THE C	Santord Fire/SPRK	
SPRK-12-17-29969	2925 BEECHTREE DR SANFORD, NC 27330-	0	0	12/12/2017	ASSOCIATED FIRE PROTECTION, INC.	(919)553-4021	FIRSTHEALTH OF THE C	Santord Fire/SPRK	
SPRK-12-17-30100	3201 INDUSTRIAL DR SANFORD, NC 27330-	0	0	12/29/2017	CRAWFORD SPRINKLER CO. OF RALEIGH	(919)828-9346	R&G INVESTMENTS	Santord Fire/SPRK	

Plan Review

Permit #	Location	Sq. Ft.	Valuation	Issued	Contractor	Phone	Owner	District	HRF
SPRK-12-17-29985	145 MAIN ST W SANFORD, NC 27330-	0	0	12/21/2017	STERLING-EULISS ENTERPRISES, LLC	(919)771-6677	4A PROPERTIES LLC	Santord Fire/SPRK	

Tent

Permit #	Location	Sq. Ft.	Valuation	Issued	Contractor	Phone	Owner	District	HRF

SPRK-12-17-29992 115 CHATHAM ST 0 0 12/15/2017 GRAND RENTAL STATION (919)210-9680 SANFORD BUGGY BUILD Sanford Fire/SPRK
SANFORD, NC 27330-

Number of Sprinkler Permit: 10 Valuation Total: \$0.00

BOC Agend
1-16-2018
PG 000067

Grand Totals:	36,350 sq ft.	\$2,361,283.50	Total Permits Issued: 205
----------------------	----------------------	-----------------------	----------------------------------

ITEM #:
VII. A.

LEE COUNTY AGENDA ABSTRACT BOARD OF COMMISSIONERS MEETING

(Use the Down or Up Arrows to move between fields of the Form)

MEETING DATE: January 16, 2018

SUBJECT: Public hearing regarding the lease of space in a spec building at CCEP.

DEPARTMENT: Administration

CONTACT PERSON: Whitney Parrish/John Crumpton

TYPE: Consent Agenda Action Item Public Hearing Information

REQUEST	To hold a public hearing regarding the lease of space in a spec building at CCEP.
BUDGET IMPACT	Up to \$325,000 for up to 24 months
ATTACHMENTS	Draft copy of the MOU between the City of Sanford, Lee County, SAGA, Samet Properties LLC, and Central Carolina Enterprise Park, LLC, Copy of Notice of Public Hearing
PRIOR BOARD ACTION	N/A
RECOMMENDATION	Hold a hearing and proceed with voting at a future meeting.
SUMMARY	

The County is proposing to participate in leasing a building owned by Samet Properties LLC, which will be located at Central Carolina Enterprise Park. Bob Joyce with SAGA will give a presentation to the Board concerning the benefits of participating in the spec building. Once the building is completed, the City of Sanford and the County of Lee will each lease the building for \$13,541.67 per month, for up to twenty-four months with a total spent from the Lee County General Fund of up to \$325,000.00. Attached is a draft copy of the MOU between all parties. At this point, we are holding a public hearing to receive input from the community. If the project is approved, at a future board meeting a lease will be presented.

NORTH CAROLINA

Memorandum of Understanding

LEE COUNTY

THIS MEMORANDUM OF UNDERSTANDING, made and entered into this _____ day of _____ 2017, by and between LEE COUNTY, a North Carolina body politic corporate in nature, hereinafter referred to as "County", the City of Sanford, a North Carolina municipal corporation, hereinafter referred to as "City", C C Enterprise Park, LLC., a North Carolina limited liability company, hereinafter "CCEP", Sanford-Lee County Partnership for Prosperity d/b/a Sanford Area Growth Alliance, a nonprofit corporation, hereinafter referred to as "SAGA", and Samet Properties, LLC, hereinafter referred to as "Samet."

WITNESSETH:

CCEP is the owner of a +/- 15 acre tract of land located in Lee County, North Carolina and more particularly described on Exhibit A (I will need to get a map of the whole park) attached and incorporated by reference, hereinafter referred to as "Site". CCEP and Samet wish to cause construction of a Spec Building on the site, located on Parcel Identification Number _____ and more particularly described on Exhibit B (I will need to get a map of the parcel). Once construction of the building has taken place, the City and the County agree to enter into a lease agreement for the site. In consideration of the foregoing and in consideration of various reciprocal promises and undertakings herein set forth, the parties agree as follows, consistent with North Carolina General Statute 158-7.1:

1. CCEP agrees to contribute the land for the construction of the shell building and agrees to enter into necessary agreements with Samet, who is responsible for building the shell building. The building to be constructed is more particularly described on Exhibit C (need a drawing of the building).
2. Samet will cause the construction of a 100,000 +/- square foot building on the site, to its completion. Samet shall secure all financing for the construction of the building and will be wholly responsible for all costs associated with building.
3. Samet will use its best efforts to cause said building to be completed to its finished state of completion on or before _____.
4. Samet will remain the owner of the building until it finds an end user, either by sale or lease. Samet will use its best efforts to find an end user who will provide a significant number of jobs paying at or above county average wage. Prior to entry of a lease/sales agreement with an end user, Samet will provide SAGA, the City and the County with information regarding the end user including the anticipated number of jobs that will be created, average wage, and trade of business.
5. Once the building is complete, the City and the County will enter into a lease agreement with the owner of the building. The terms of the lease will be detailed in the lease agreement, with rent not to exceed \$27,083.33 per month or up to \$325,000.00 per year, split between both units of government, for up to twenty-four months after completion of the building. In the

event the lease is terminated early due to a lease or sale to a new end user, the obligation to pay rent shall cease and any rent prepaid shall be reimbursed to the City and County.

- 6. The City and the County will lease all or a portion of the building allowing SAGA to use the space to market the City and the County as a whole. SAGA shall use its best efforts to market everything the City and the County has to offer businesses, including but not limited to, our workforce, schools, shopping, restaurants, industrial parks and housing opportunities.
- 7. During the lease, SAGA agrees to use the building as a way to entice new businesses to come to Lee County or to relocate or expand in Lee County. New business will help to increase the tax base and allow more job opportunities for citizens. SAGA will conduct site visits and events at the site showing the opportunities businesses have to locate to the City and County.
- 8. SAGA will provide a quarterly update to both the Commissioners and the Council, summarizing their efforts to market the area by using the building and providing an update on how many site visits have been conducted, the feedback from those visits, and any negotiations with potential end users. SAGA will be responsible for any costs associated with marketing the area impacted by this project.
- 9. This agreement is governed by and shall be construed in accordance with the laws of the State of North Carolina; venue of any action shall be in the general courts of justice in Lee County.
- 10. This Memorandum of Understanding shall terminate if an end user of the building is found before the parties enter into a lease agreement, if the building is not constructed to full occupancy, or when the lease terminates.

IN TESTIMONY WHEREOF, the parties have executed this Agreement as of the day and year first above written.

LEE COUNTY

By: _____

CITY OF SANFORD

By: _____

SAMET PROPERTIES, LLC

By: _____

CENTRAL CAROLINA ENTERPRISE PARK, LLC.

By: _____

SANFORD AREA GROWTH ALLIANCE

By: _____

